

Syllabus: Context: Ideas

Architecture: the New Creative Space

Studio Site: Hawthorne, California, Tesla Motors Design Studio

Architecture 4006
Spring 2016
Columbia University
Graduate School of Architecture, Planning and Preservation

Michael Bell, Professor of Architecture
Hamza Sarout, Studio Critic, Daylighting Assistant

Studio Phases: The studio will follow three cumulative phases.

1. Manufacturing Light: Absorbance and Reflection. Experimental work in radiance and day-lighting.
2. Up-Dating the Mock Up: the Case of the NY Times, Renzo Piano, and the Lawrence Berkeley Labs: We will propose new revisions of the Piano/LBL case study.
3. The Architecture of the Creative Space: Hawthorne, California. Project in context with a formal program.

Studio Travel: The studio will travel to San Francisco, Palo Alto, Fremont and Hawthorne, California. Michael Bell will attend all studio sessions. Hamza Sarout will attend one studio sessions as well as hold a software workshop each week in day-lighting and finite element analysis software. Times will be coordinated to suit entire studio.

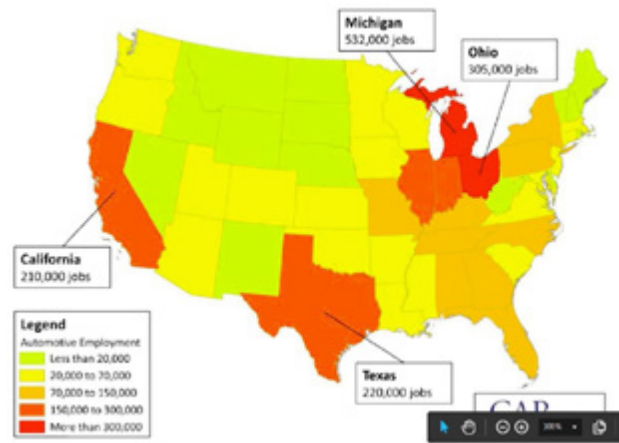

The automotive industry spends nearly \$100 billion globally on R&D 18 billion per year in the U.S. alone.

Automakers spend an average of \$1,200 for research and development (R&D) per vehicle.



Is this a Factory: The Auto Industry fuses with Silicon Valley: Fremont, California, Tesla Motors

Source Jiawei L (Hill, Kim, Debra Menk, Bernard Swiecki, and Joshua Cregger. (2014). "Just How High-Tech is the Automotive Industry?" Center for Automotive Research. Page 9. January 8, 2014. <<http://www.cargroup.org/?module=Publications&event=View&pubID=103>>.)

A Technological and Manufacturing Tour de Force and its place it's in the city: Fremont is home to the engineering and manufacturing plant for Tesla and its role in producing electrically powered cars is well known. Fremont is also the host city of the first extension of the Bay Area Rapid Transit system (BART) since the subway was founded in 1957.

While the Tesla plant is itself not a new construction – it was the former General Motors plant and then a partnership between GM and Toyota – the recreation of the plant by Tesla as a visionary new production facility for a new automobile is. In Fremont one finds a formidable story that is both old and new at once: the private car meets mass transit here in a vivid new way but also the car and its entire process of design, engineering and more so material knowledge is re-conceived and invented. In this same context the mass transit station seems stalled—even

as it promises a new linkage and all the economies of public transportation it does not offer a great new urban vision.

In the history of manufacturing, factories of all kinds, we have seen historical examples of visionary works of architecture. We have also seen similar investment in the capacity of worker housing and urbanism that is parallel to and commensurate with the new factories.

Our studio will focus on the reinvention of the creative space--the studio and lab that precedes the factory.



The Corporate Campus as Creative Empire: Private (but with a 10,000 car garage): The Valley Architecture matures: the urbanism lags behind and relies on automobiles and a low-density form of development. Apple's new campus, futuristic in scope and material engineering hosts a 10,000 car parking garage as testimony to the Bay Area's lack of public transit.

Cupertino, California: As Apple undertakes a new corporate campus of infrastructural scale what are the parallel implications for areas of Cupertino adjacent to the campus? Is there a compensatory vision for architectural work in the program of housing, retail, government and public spaces? What is the scope of creative concern for today's leading technology companies.

Drone Video: Apple Campus 2, Cupertino, Ca. Fall 2014. The campus dwarfs its neighbors but also will be relatively unseen from outside the property's perimeter. At several billion dollars it is also a relatively small expenditure in the scale of Apple's financial means. It fuses infrastructure and architecture in ways that are moderated by high levels of engineering and aggregate talent and coordinated resources.

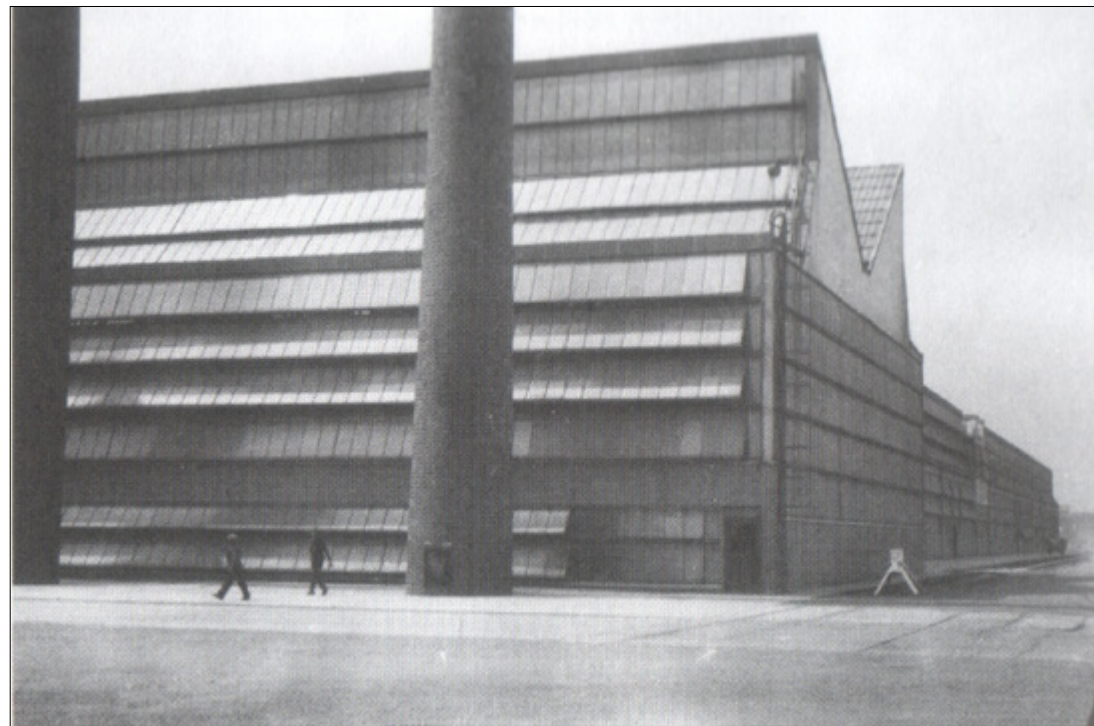
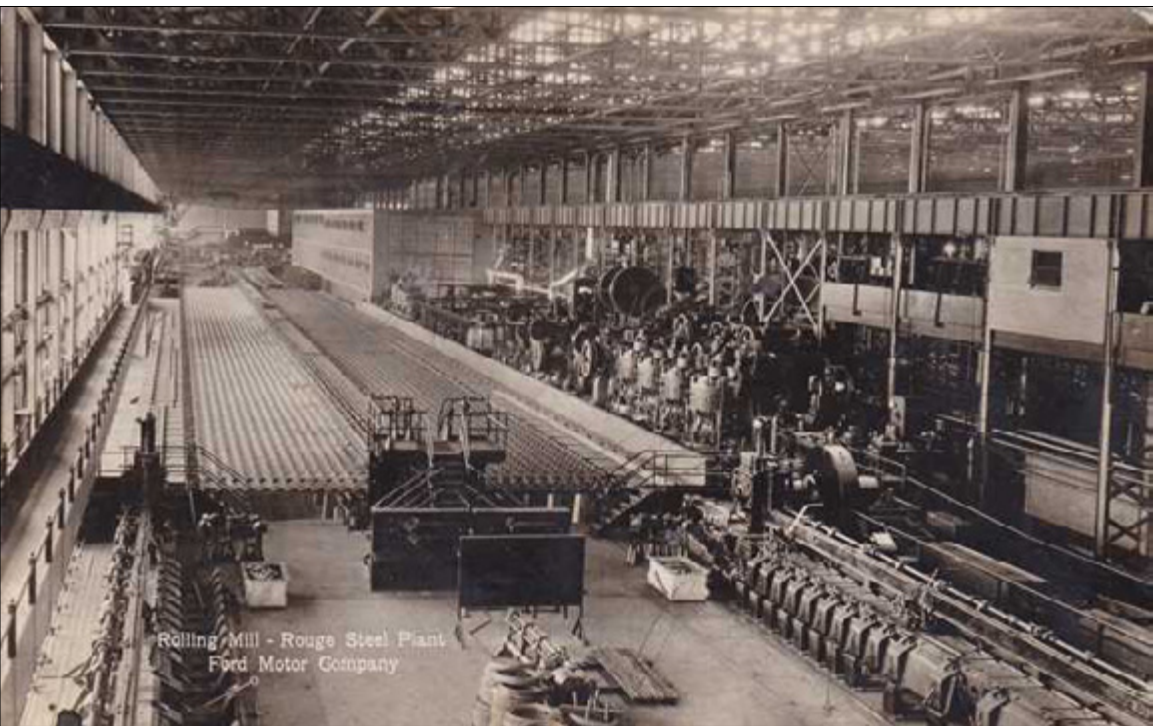

Earlier Paradigms: The factory was designed to be built out of its own products: today's factories are rapidly changing and in doing so challenging the definition of a factory.

1917-28:

Albert Kahn: Ford Rouge Steel Rolling and Glass Plants: A constituent material / steel / rolled in architectural and automatic shapes. A conflation of material as both building and commodity. The chemical and labor innovations beneath the scene are more difficult to discuss but present. (note photography by Walter Gropius or Ise, 1928--Negative Bauhaus archive, Berlin).

1973:

Despite the industrial violence an aesthetic prevails that both stalls and enables change: The image of the factory as laden with strife helps forge the environmental movement. Yet also seems to seed a recoiling from industrial imagination. Ford Motor Company: River Rouge Plant, Dearborn, Michigan.

2015:

Tesla: the electric car production line is antiseptically clean and a deep hybridization of computing and manufacturing. The works are as likely to operate a computer as use a hand held tool.



Above: Tesla engineers have often come from Apple: Work at Apple and Tesla often advances new materials that alter the commodity aspect of new products—materials science, chemistry, physics alter mechanics and manufacturing. An example: Mike Pilliod (Tesla materials engineer formerly at Apple): Patent application: a topologically enhanced silica molecule for use as binding agent in iPhone production. The topologically enhancing coating can take the form of functionally activated nano-silica particles. In one embodiment, the nano-silica particles are functionally activated using amine groups. The thermo-plastic composite can be used to join a number of metal components together to form a load bearing structure.

2_chemical_engineering

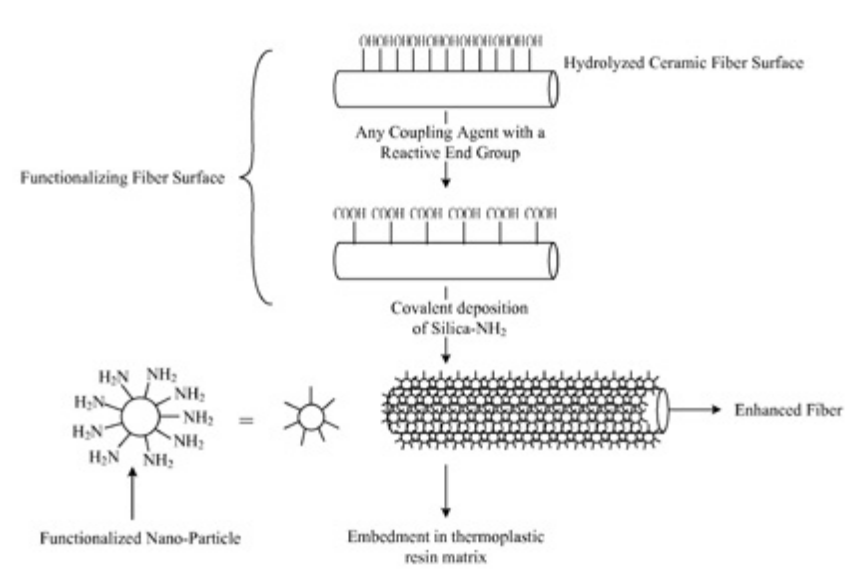
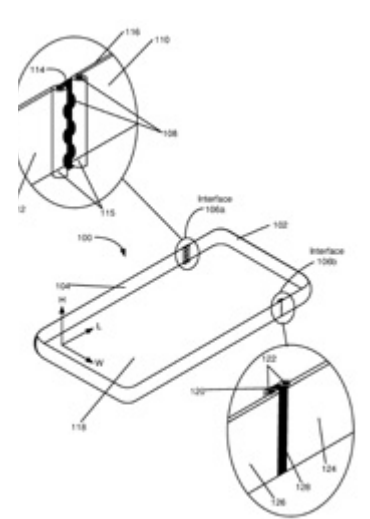

Figure 4

3_topologically enhanced_molecule

4_manufacturing_affected



5_physics_balance_center_of_gravity/mass

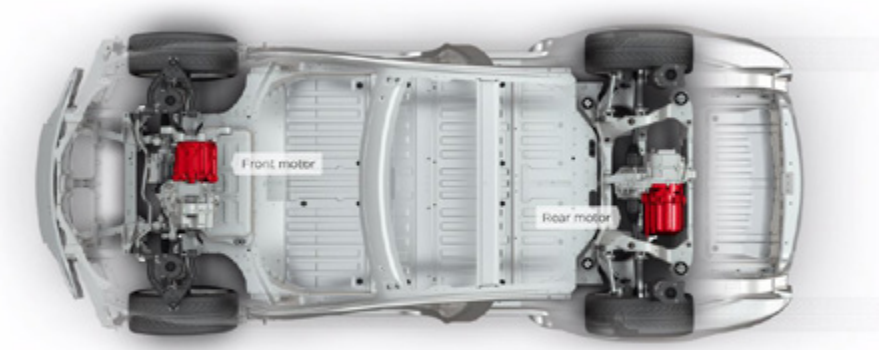

6_global_attention



1_electro_magnetics

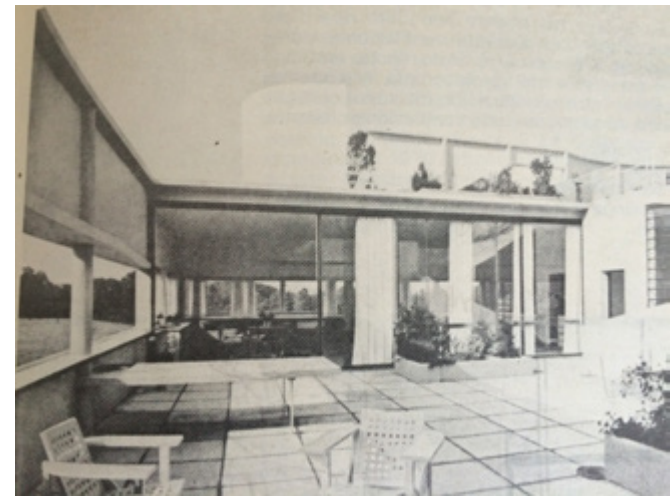

9_architectural_topology

8_vertical_ribbon_window

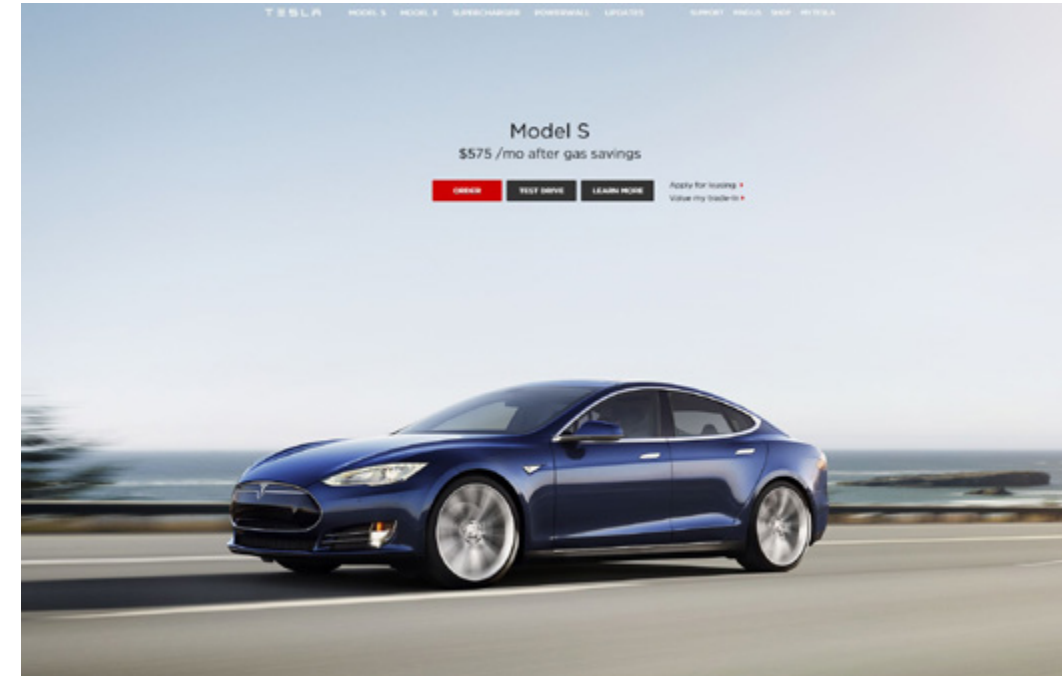

7_aerodynamics

Studio Phase 3: A Design Studio for a Company that Engages:

Electro-Magnetics, Light, Electricity, Chemistry, Physics (alter manufacturing) (create: acceleration, weight distribution, energy), Attention, Navigation, Motor Skills, Sight/Vision, Aerodynamics, Topology.

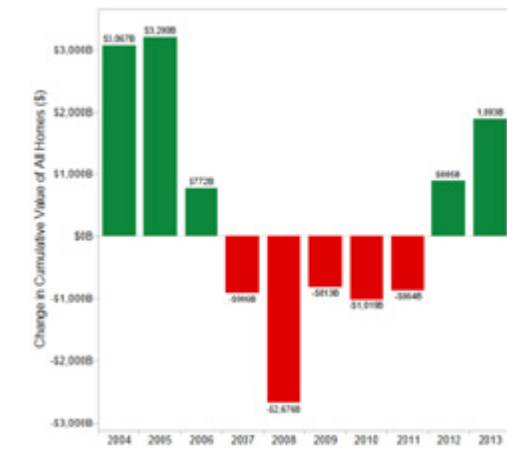
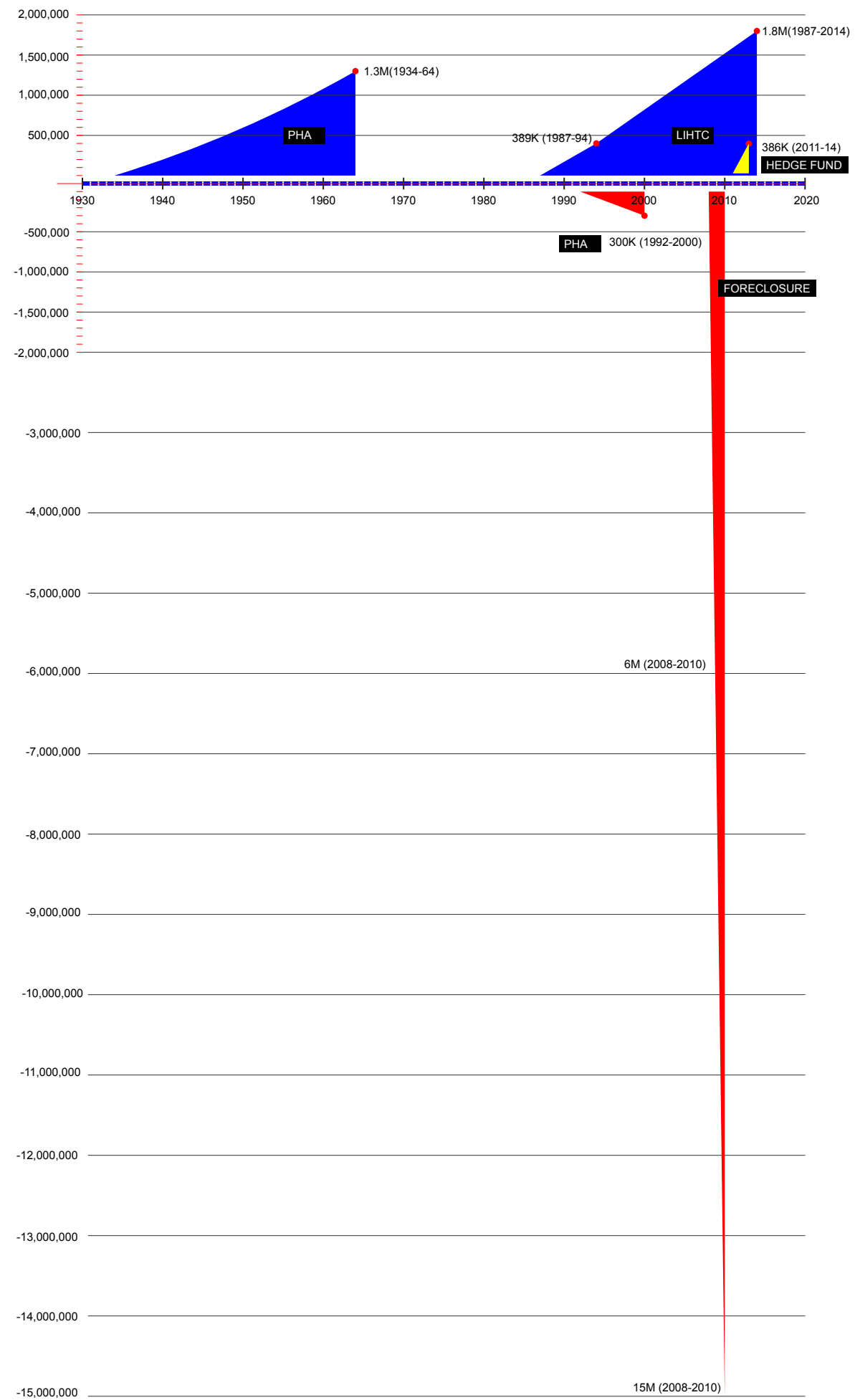

Bell_Seong

A backdrop of economic change: Debt, Houses and Cars-
 each creative zone is newly linked in today's changing
 economy. Public Housing, Affordable Housing, Foreclo-
 sures, Reductions in Public Housing, Private Equity re-
 buys the suburbs.

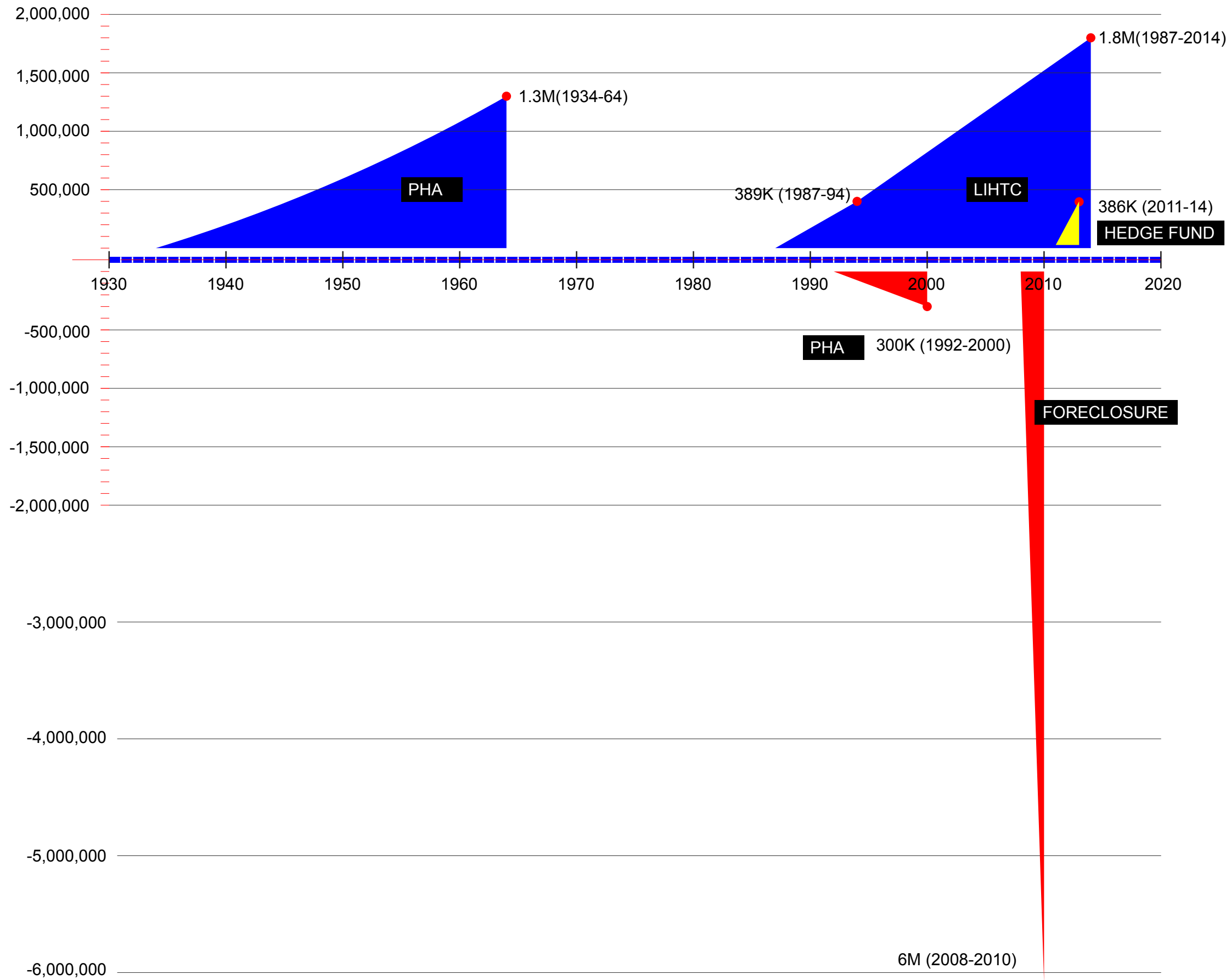

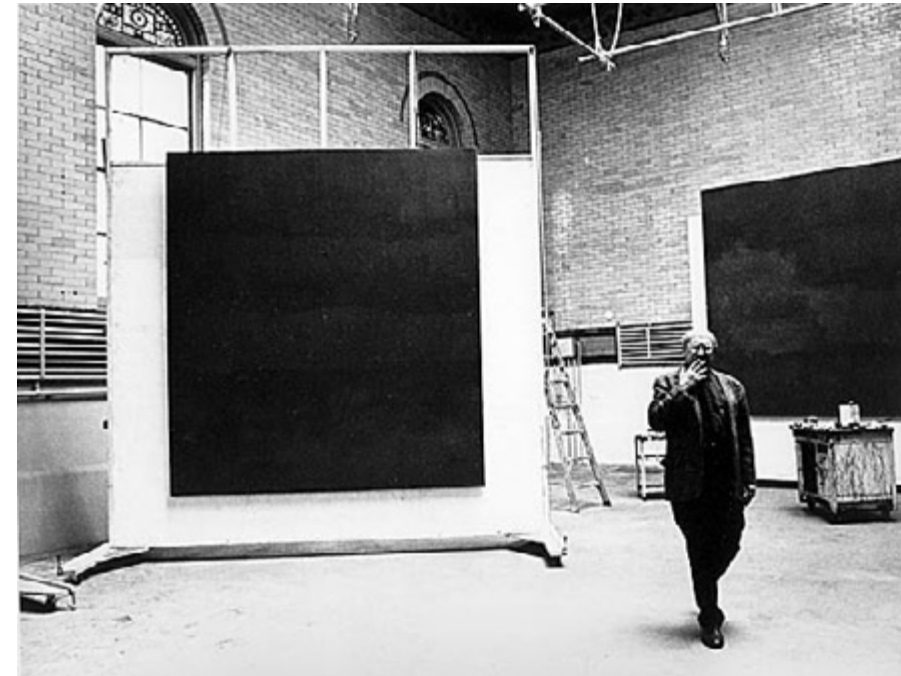
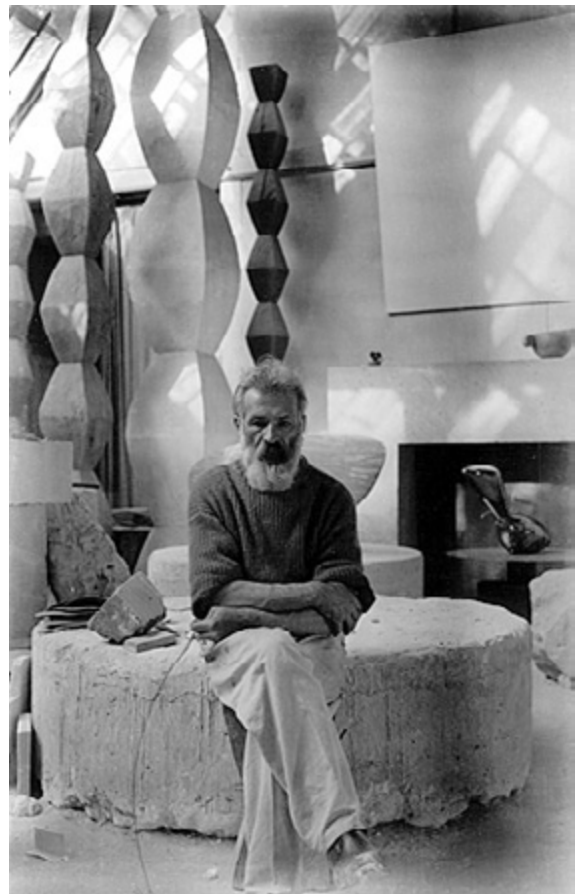

the Artist: The Architecture of the Creative Space

Constantin Brancusi in his studio.

Pablo Picasso, in his home and studio.

Mark Rothko in his 69th Street studio with Rothko Chapel murals, c. 1964, © Hans Namuth Estate, courtesy Center for Creative Photography, The University of Arizona. His work on the Rothko Chapel paintings, originally commissioned by John and Dominique de Menil for the University of St. Thomas in Houston, Texas, occupied Rothko between 1964 and 1967. In turning away from the radiance of the previous decade, Rothko heightened the perceptual subtlety of his paintings, making distinctions between shape and ground more difficult to discern. He also transformed the impact his canvases have on the experience of space, which is now characterized by a sensation of enclosure. This quality, which lends itself to meditation, can be clearly related to the spiritual nature of a chapel.

Architecture 4006
 Spring 2016
 Columbia University
 Graduate School of Architecture, Planning and Preservation

Michael Bell, Professor of Architecture
 Hamza Sarout, Studio Critic, Daylighting Assistant

What is a creative act?

A voice is speaking about something. Someone is talking about something. At the same time, we are shown something else. And finally, what they are talking about is under what we are shown. This third point is very important. You can see how theater cannot follow here. The theater could take on the first two propositions: someone is telling us something, and we are shown something else. But having what someone is telling us be at the same time under what we are shown—which is necessary, otherwise the first two propositions would make no sense and be of little interest. **We could put it another way: the words rise into the air as the ground we see drops further down. Or as these words rise into the air, what they are talking about goes underground.**

What relationship is there between the work of art and communication? None at all. A work of art is not an instrument of communication. A work of art has nothing to do with communication. A work of art does not contain the least bit of information. In contrast, there is a fundamental affinity between a work of art and an act of resistance. It has something to do with information and communication as an act of resistance.

Source: Two Regimes of Madness, Texts and Interviews 1975-1995 / Gilles Deleuze (1925-1995), edited by David Lapoujade, translated by Ames Hodges and Mike Taormina pp. 312-324



The CREATIVE audience tries to see what they also cannot hear.

The Conversation, Francis Ford Coppola, Writer, Producer, Director

First Principles or Multiple First Principles

“I think it’s important to reason from first principles rather than by analogy. The normal way we conduct our lives is we reason by analogy. [With analogy] we are doing this because it’s like something else that was done, or it is like what other people are doing. [With first principles] you boil things down to the most fundamental truths...and then reason up from there.”

Elon Musk / Source: https://www.youtube.com/watch?v=L-s_3b5fRd8

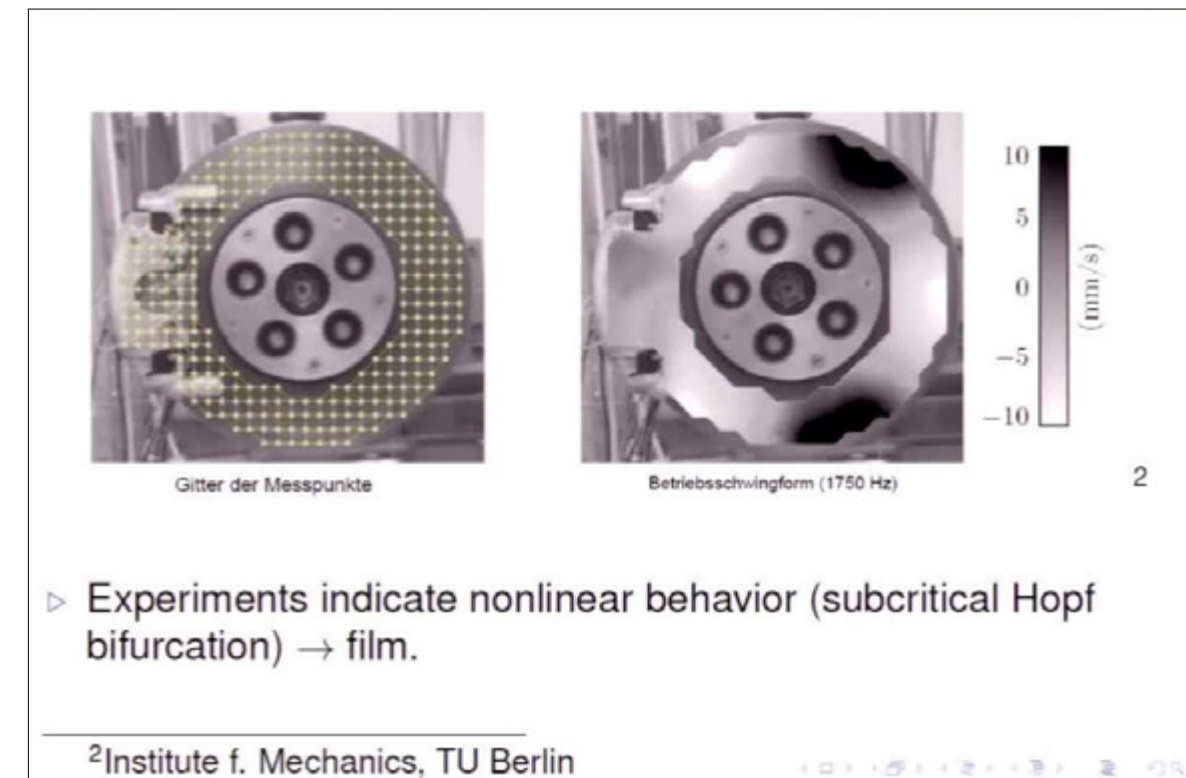

A Sample Mathematic and Engineering Creative problem:

Material Failure: Non Linear Behavior and Problems Arising in the Analysis of Disk Brake Squeal

<https://www.filepicker.io/api/file/ehfF8ZITVaMJ3xVXMuvq>

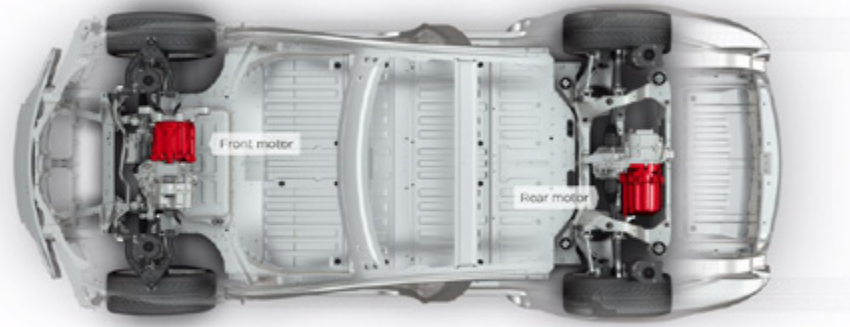

Electric Gravity

In preparing a studio that looks at the Future of the Creative Space and in particular at how the city's prominent new industrial constituent, electric automobile manufacturer, Tesla Motors, may affect the future planning of the city, Professor Skilling's book and its opening chapters are still a remarkable guide and Skilling is indeed quite accessible and at times metaphoric, abstract and most of all spatial in his tone and phrasing. He language is at time luxurious even as he is knows the consequences of his subject.

Vector and Scalar Fields

Skilling opened his text with dedicatedly architectural and accessible language and example. In explaining a distinction between vector and scalar fields as he began to place electric waves in the context of physics he used the spatial and time based dimensions of a room to create essential distinctions: In offering an example of a scalar field Skilling described a process of measuring the temperature at various points in a room. While the results may vary Skilling explains that one cannot associate vector components with temperature. As an alternative he described a similar measurement at multiple locations for an object/mass and its relation to gravity—regardless of location the same magnitude and downward direction of gravity is consistent. Gravity is here presented as a vector field—its direction and magnitude are given as consistent and the placement of an object in space (in this case the room) does break down into a consistent vector component afforded by gravity. The distinction, artfully explained, opened the text book and unfolds as the basis of his work on magnetic and electric fields we explains in the context of vector fields. Skilling outlines relations between magnetic force and the chemistry and physics of electricity. Skilling was more than aware of the implications of his work but nonetheless also reveled in the spatial and force driven reading of electro-magnetics—more so in the conceptual nature of the work which in his text is largely carried by words and diagrams. Not actual microscopic observation.

An Electric (high performance car): 67 Years Later

The electric automobile in the case of Tesla brings both gravitational and electrical fields to the fore in a deeply sophisticated consumer product: an automobile. The electrical power employed by Tesla provided by chemical battery and electromagnetic engine alters the equations of acceleration and torque (and the human experience of acceleration in a car) that have long defined how a car is propelled from rest. The application to a car instantly brings forth inherent problems of gravity and its vector path. The car at rest on the ground is of course not complex but while in motion that essential physics is altered by the variable speeds, acceleration, deceleration—the balance of mass in the car. The electric car with its battery pack forming the floor pan has a newly lowered center of gravity—the application of electricity to car design here allows an alteration of the cars dynamics but in a more essential (that is scientific) way the electric car conflates the physics of gravity with the vector fields of electricity that define or instigate the mass in motion. As exotic (if not convoluted) as this all sounds the Tesla Model S is still (simply) a car (taking up space in parking lots / being driven as a commuting tool)...in other words: all of this genius barely spills outside of the cars beautifully shaped form and newly conflated authority of electricity and gravity. Is brilliant manufacturing provides a deeply new type of car but what would be possible if Tesla's engineering and energy capabilities were allowed to affect architecture—that is we could make use of Professor Skilling's depth of abstraction and bring a deep sense of these properties to architecture.

Professor Skilling, of course, did not see electricity and electromagnetic theory as bound to purpose. His text is a necessary conflation of physics and chemistry but he was also conceptual and even abstract in his methods. Electromagnetic energy moves through things that—seem to, but not actually—stand still. Electro-magnetic waves are a constituent of everything material. In architecture this seems barely acknowledged except for its direct and deeply choreographed applications. It is in effect isolated from daily life but used to enable virtually every aspect of it. Tesla and Fremont have no immediate plans to alter this stable relationship (the car for the moment is the goal and the deep

SCALAR FIELD // temperature

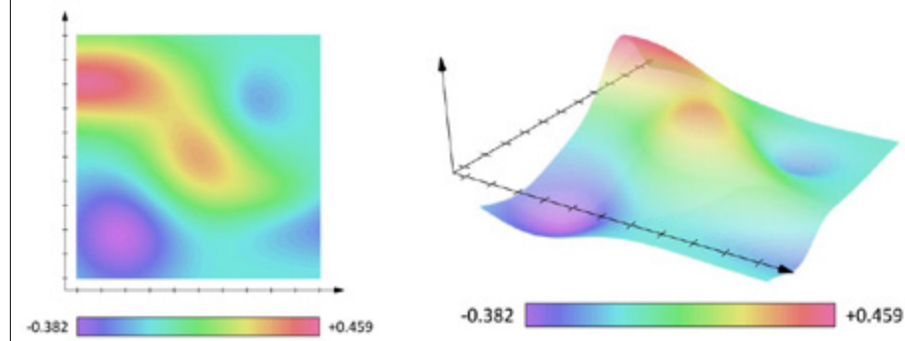

A scalar field such as temperature or pressure, where intensity of the field is represented by different hues of color.

The temperature at any point is characterized by a function $T(r, \theta, \phi)$. In other words, the value of this function at the point with coordinates (r, θ, ϕ) is a temperature with given units. The temperature function $(, ,) T r \theta \phi$ is an example of a "scalar field." The term "scalar" implies that temperature at any point is a number rather than a vector (a vector has both magnitude and direction)

H_Vector vs Scalar Field ABSTRACT ENGINEERING STUDIO // MICHAEL BELL / YAOHUA WANG

Creativity + Mobility and Cities: Zhe Fan, GSAPP, *Abstract Engineering*, Fall 2015

VECTOR FIELD

Definition:

In vector calculus, a vector field is an assignment of a vector to each point in a subset of space. A vector field in the plane, for instance, can be visualized as a collection of arrows with a given magnitude and direction each attached to a point in the plane. Vector fields are often used to model, for example, the speed and direction of a moving fluid throughout space, or the strength and direction of some force, such as the magnetic or gravitational force, as it changes from point to point.

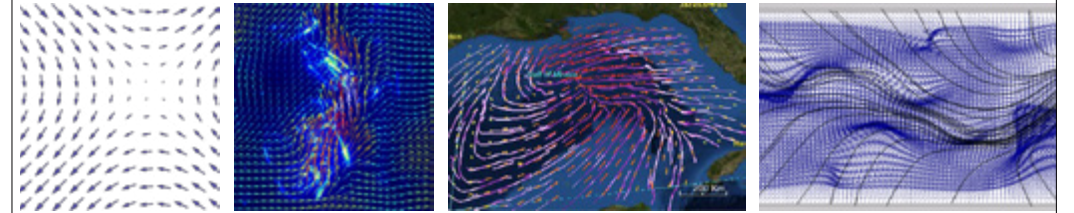

H_Vector vs Scalar Field ABSTRACT ENGINEERING STUDIO // MICHAEL BELL / YAOHUA WANG

Creativity + Mobility and Cities: Zhe Fan, GSAPP, *Abstract Engineering*, Fall 2015

sophistication of physics and chemistry at play here will remain experiential at the level of driving) but as Tesla moves its focus towards home energy and in particular home batteries and solar power an architect—that is, us—wonders how long the resistive capacity of the houses, the car and city as we know it can hold? That is for how much longer we will constrain the innovative capacity embedded in every day technology from altering the base instruments they seem to give life support to. At the moment Tesla's innovation promises a new life span for the car; and indeed for the single family house and its cartographic deployment but will Tesla innovations unfold to create a wider new architectural and urban field? One that alters the literal and conceptual dimensions and forces that we imagine we manage in creating cities and buildings?

A New Industrial Technical Frontier:

Fremont for our studios purposes is a new frontier for architecture. Not as a parametric vision for assembly via Tesla's robotics or computer controlled production but instead as the electrical/physical unbounding of the concepts that are part of the company's technical genius. Tesla as a technology company actually bases much of their faith in the ability to alter production (at all levels: financial, mechanical, etc) by advanced research into materials. While the electrical energy source alters the car's environmental impact it is a focus on adhesives, or materials strength and weight or indeed in chemical engineering of (quasi-new) materials that precipitates new ideas or means for tooling or mechanical engineering. Material and material meeting electricity drive Tesla—but one wonders: does the image and the fantasy and fascination of the car remain in ways that we could unfold and indeed does the promise of Tesla come outside the car in the wider environment.

It is difficult to know which is in effect more abstract: the beauty of the car? Its environmental techniques? Or the conceptual and then scientific work on material that alters the financial and mechanical models of the automotive industry (of a major commodity industry). The final entry here is where we begin: what happens when the conceptual work that drives Tesla is unfolding beyond the property limits of the factory, beyond the target physics of the car....

Architecture: vector aspects of gravity and electricity. Thermal heat gain and loss—hours of labor both human and machine spent in its realization. Have we been living for decades and indeed a century inside a misbegotten conflation of weight and weightless—using electricity and its vector means to shore up otherwise physically stable/presumably timeless and direction-less ideal of structure? Televisions on and supplied by current inside plywood diaphragms—have we suppressed electricity in favor a quasi-low-tech mechanics and more so elemental idea of architecture?

Can the thinking of not just Tesla but indeed scores of Bay Area technology companies spill over the corporate walls and into urban and spatial thought? To achieve this we would need to believe that a new type of receiver is possible: that is, that the technologies are not born of a given commodity that sustains their economics. What becomes of the car if it is abstracted into a new mechanism but more so what happens to architecture if its sustenance by a denied life support is allowed to surface?

Architecture: vectoral aspects of gravity; scalar aspects of electricity. Thermal heat gain and loss—hours of labor both human and machine spent in its realization. Have we been living for decades and indeed a century inside a misbegotten conflation of weight and weightless—using electricity and its scalar means to shore up otherwise physically unintelligent vectoral structure? Televisions on and supplied by current inside plywood diaphragms: nailed horizontally to 2 x 4 studs a quasi-gravity is induced to move horizontally. The answer is yes. We have.

Can the thinking of not just Tesla but indeed scores of Bay Area technology companies spill over the corporate walls and into the street, into urban planning? To achieve this we would need to believe that a new type of receiver is possible: that is, that the technologies are not born of a given commodity that sustains their economics. What becomes of the car if it is abstracted into a new mechanism but more so what happens to architecture if its sustenance by a denied life support is allowed to surface?



Optic Signals, Galvanized, Steel. Cantilever



Iron, Water, Pressure



Timber, Oil Soaked, Galvanized Bolts, High Voltage, Catenary Wires



Catenary Wires, Low Voltage Electricity



Catenary Wires, Communications



Asphalt, Slumping



House, Housing



Everything else: a temple of infrastructure



“Albuquerque, New Mexico, 1972,” by Lee Friedlander. He said he deliberately includes “those poles and trees and stuff” that other photographers avoid.



Xiaoyu Wang: Cropped photograph from Google Streetview



Xiaoyu Wang: Power_Structure_Optic_Privacy



In the complex metropolitan environment, the city has no form. The forms of control over time, distance, money, and social space supersede any morphological analysis.

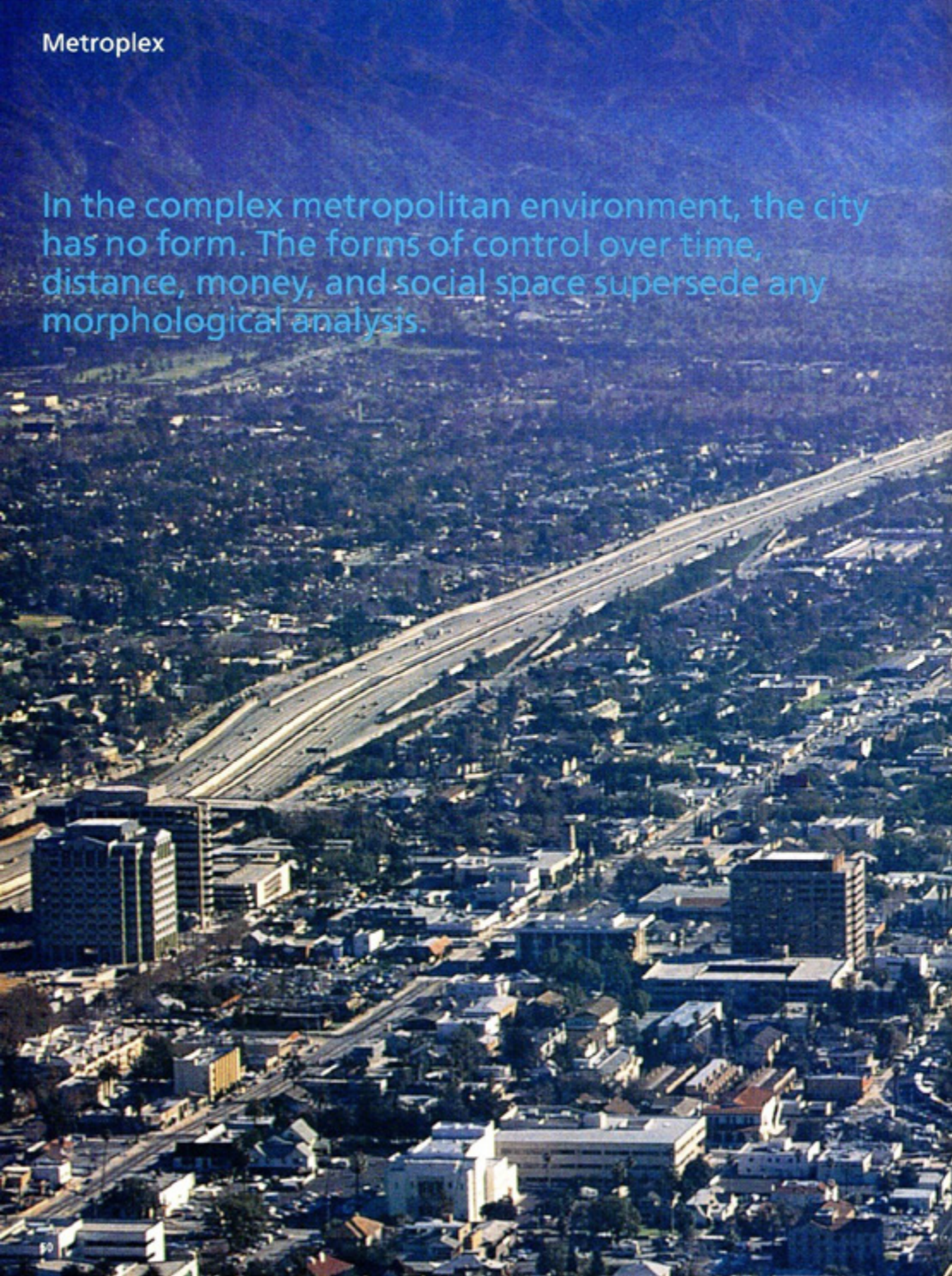

Optic Comfort: Creative Work in a Difficult Space

Far right: Specialist Richard Plum, center, rubs his eyes as he conducts trading in shares of Bristol-Myers Squibb on the floor of the New York Stock Exchange, Aug. 8, 2006.

Shares of Bristol-Myers Squibb Co. sank more than 6 percent that day as a generic drug maker Apotex Corp. Disclosed it has begun selling a cheaper version of the big pharmaceutical company's best-selling drug Plavix. That's the deal with capitalism: constant competition, constant change. Photo credit: Richard Drew, AP

Left: "In the complex metropolitan environment, the city has no form. The forms of control over time, distance and money, and social space supersede any morphological analysis." California: Excerpt: Neil Denari, Gyroscopic Horizons, 1999, Princeton Architectural Press.

Below: Houston, I 59 and Beltway 8



72 years in traffic every two days

2 billion vehicles

Urban Fragmentation produced by Focused Efforts

The fragmented landscape was made with careful attention to detail and to money:

At the Detroit Economic Club in 1944 the Secretary of the Treasury described a need for ten billion dollars a year in exported goods if the U.S. expected full employment after the war. During the 1940's, after the signing of the Bretton Woods Treaty a new United States landscape that was driven with a new level of integration of the dual mechanisms of production and finance. Production was understood through a lens of efficiency; while finance advanced towards the forms of structured leverage that are now common (and in crisis). Yet both finance and production still operated at local levels despite the international trade. Nations were largely segregate economically even if connected and the relationship of materials, goods, products and labor were partitioned into relatively local zones. They would of course become increasingly connected—and connected. You could call this the ductile era: the spectacle of cities, commerce, development, and jobs revealed itself in a tensioned constellation of cities—in the lights at night photograph above.

While a common attribute of this new landscape was a United States that could no longer provide

full employment without exporting what it produced it was still a United States based in material and labor. The country was deterritorialized by labor and economic issues but still a producer of hard goods—material economics.

Today this equation is virtually reversed—it is finance that seems to have driven production and while material is still the final equation of presence — material itself is sited at the final of many tiered steps—tranches— (far away from the real motivation which is virtually finance itself). Material is inevitable but if it can be isolated from the production of surplus all the better. So too actual labor or a paying customer. Is there an architectural result that would not critique this at its philosophical level: that is, not criticize?



Engineering An Office as Landscape / The Office as Studio
Structure, Risk, Material and Experience: **Frank Lloyd Wright, Johnson Wax**

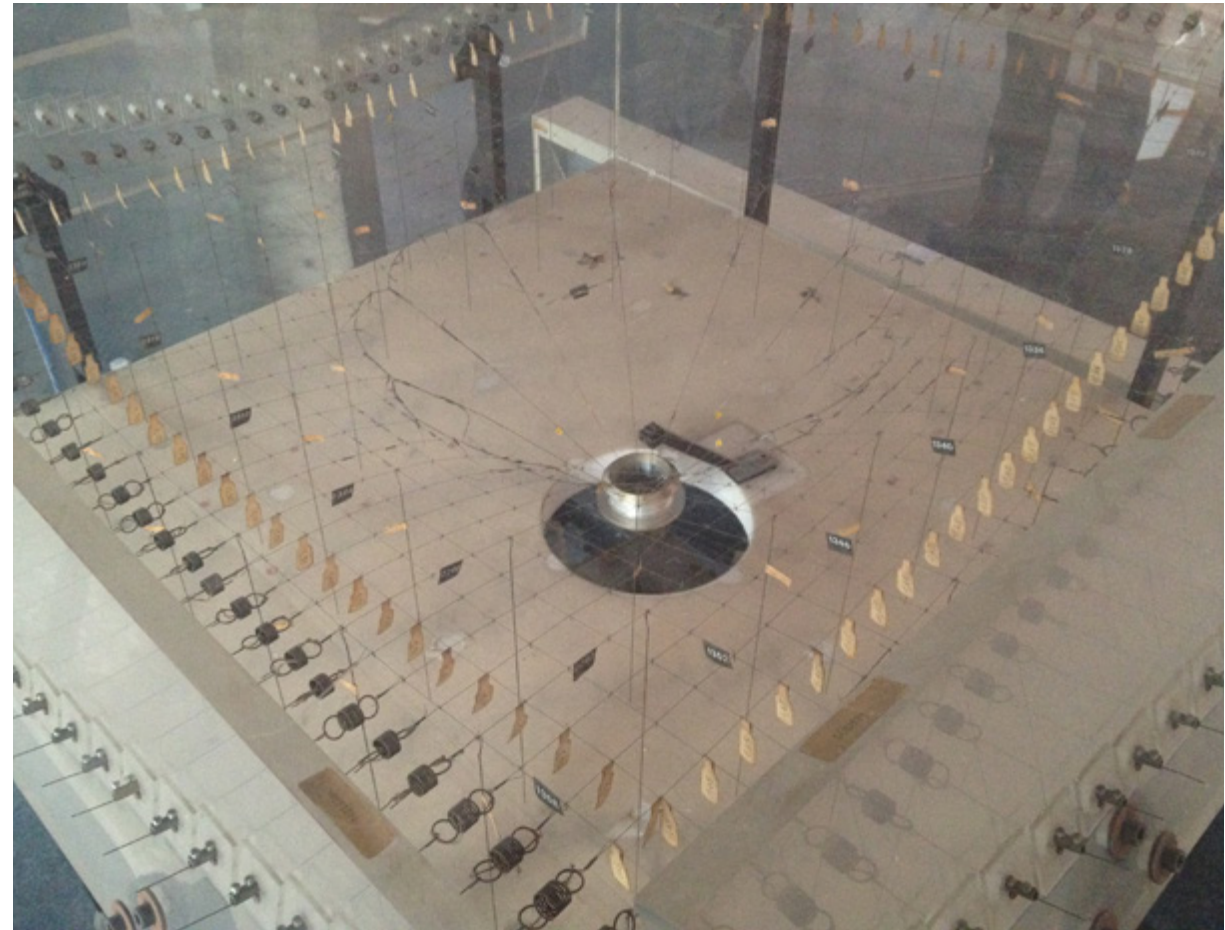
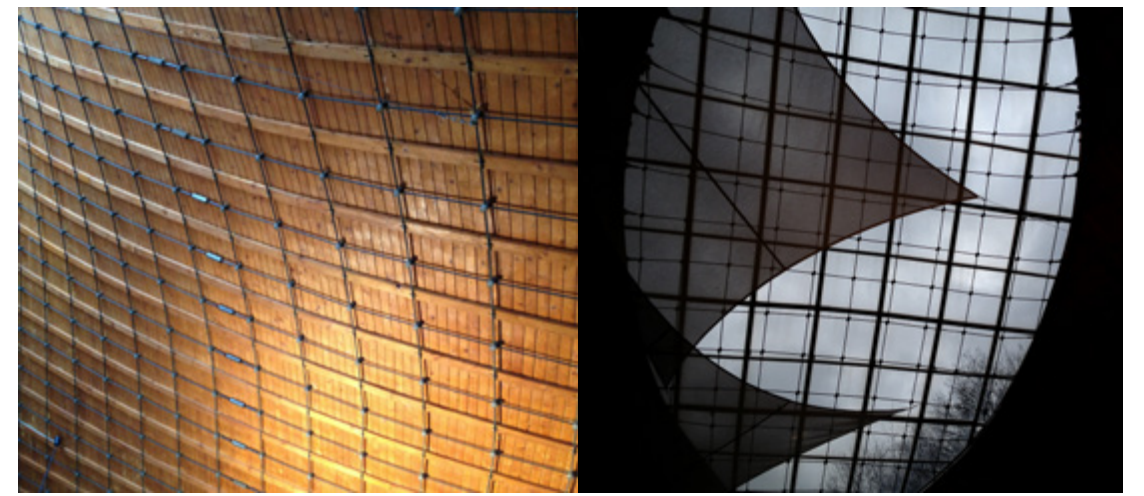
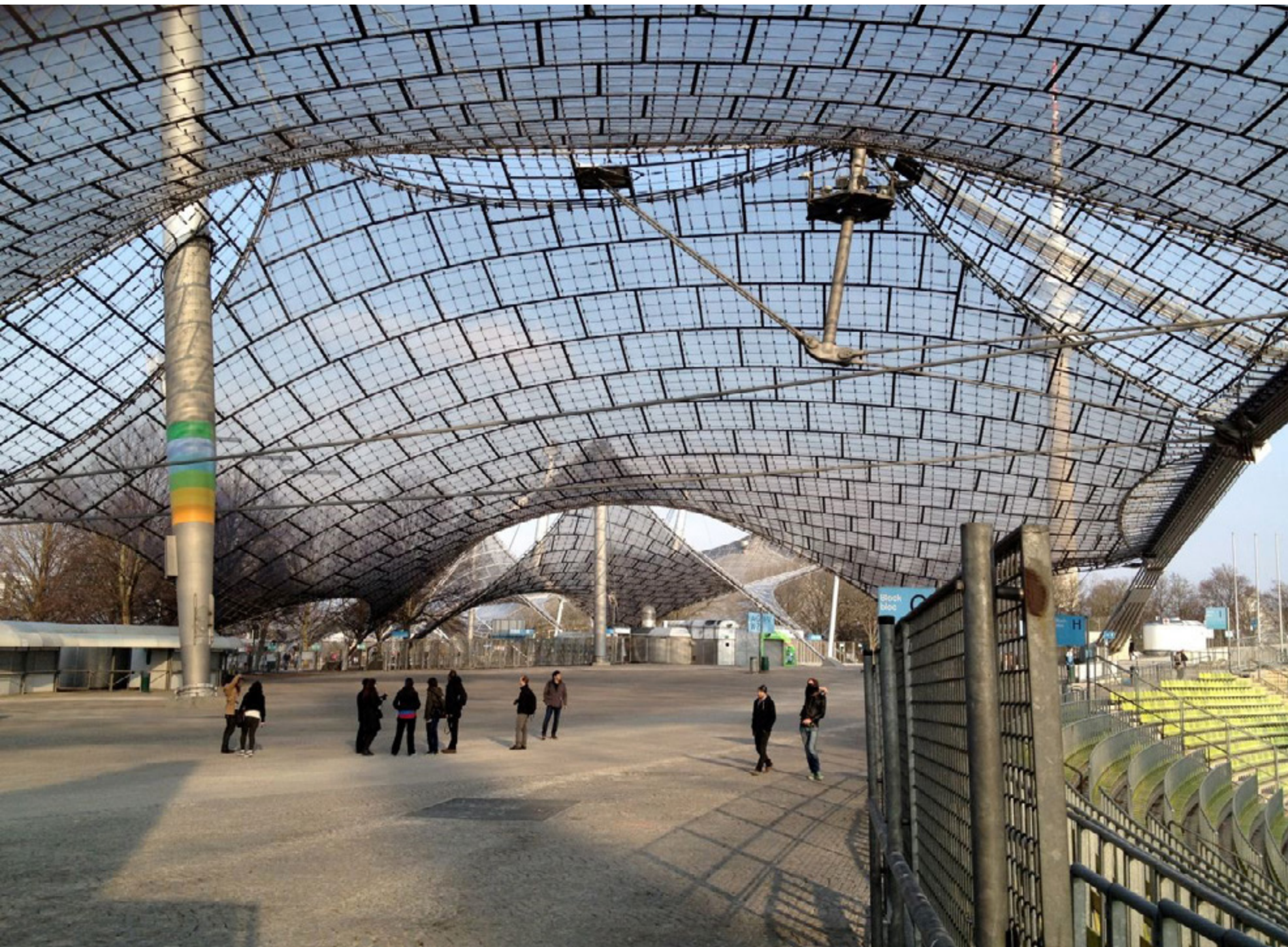

The Engineer's Creative Space: **Frei Otto, University of Stuttgart**

Frei Otto, Studio and Munich Olympic Stadium (1972)

The studio and the architecture are unified: Fusion of architecture and infrastructure: efficiency and synthesis but also as an attempt to reconcile large scale social need with emerging ideals for design, materials and engineering. Fusion of engineering and architecture: driven by material and in particular uses of membranes, tension elements and then new means of coordination. Lightweight aspects of membrane polymers involving large tensile or grid-shell roofs over massive volumes were designed and constructed for one-off events – expos, Olympics, etc... Our goal will be to consider the legacy of these projects on the surrounding areas they were designed for and see how they translate into new models for use in the US and our sites. They involve landscapes, utilities, environmental, circulation and are distinctly infrastructural.

A One to One Correlation between, Model, Analysis, Studio and Building





The office topologically compacted into a computer?

The architectural and industrial design aspects of an office--as room--are topologically folded into the computer and keyboard. The room--as much as it remains is in service of the office systems: lighting, heating, cooling and cable and communications.

Sears mail order processing

Edward Hopper (the Office at Night, 1940). Typical of Hopper, the color emits light and is indeed a source of light.

Prototype office furniture (sans room/office)

Apple Office



Curtain wall, tiled floor, fluorescent light, desk: not designed for computer screens?

Mech Systems, Air Balancing, Cold Bridging and Glare

Gordon Bunshaft, Lever House

Mies van der Rohe, The Seagram Building



Studio Phase 1: Experiments in Reflected, Scattered, Absorbed and Emitted Light

Dolores James by John Chamberlain's: John Chamberlain's dynamic agglomerations of scrap metal and used automobile bodies have been admired for translating the achievements of Abstract Expressionist painting into three-dimensional form. The whirling arabesques of color in wall reliefs such as Dolores James echo the energy and expressive power of paintings by Willem de Kooning; the heroic scale and animated diagonals suggest the canvases of Franz Kline. Like the Abstract Expressionists before him, Chamberlain reveled in the potential of his mediums. In a 1972 interview with critic Phyllis Tuchman he remarked, "I'm sort of intrigued with the idea of what I can do with material and I work with the material as opposed to enforcing some kind of will upon it." Chamberlain emphasized the importance of "fit," or the marriage of parts, in his sculpture. As in other early works, the various elements of Dolores James stayed in place by virtue of careful balances when the sculpture was first assembled; later, the work was spot-welded to ensure its preservation.

Chamberlain's oeuvre appeared in the context of late-1950s assemblage or Junk Art, in which the detritus of our culture was reconsidered and reinterpreted as fine art. On some level, his conglomerations of automobile carcasses must inevitably be perceived as witnesses of the car culture from which they were born, and for which they serve as memorials. There is a threatening air about the jagged-edged protuberances in Chamberlain's sculptures, and the dirty, dented automobile components suggest car crashes; the artist, however, preferred to focus on the poetic evocations that his sculptures elicit. Source: Jennifer Blessing



John Chamberlain, installation view, Dia:Beacon, Riggio Galleries. © John Chamberlain/Artists Rights Society (ARS), New York. Photo: Michael Bell Architect, Galia Solomonoff, OPEN OFFICE

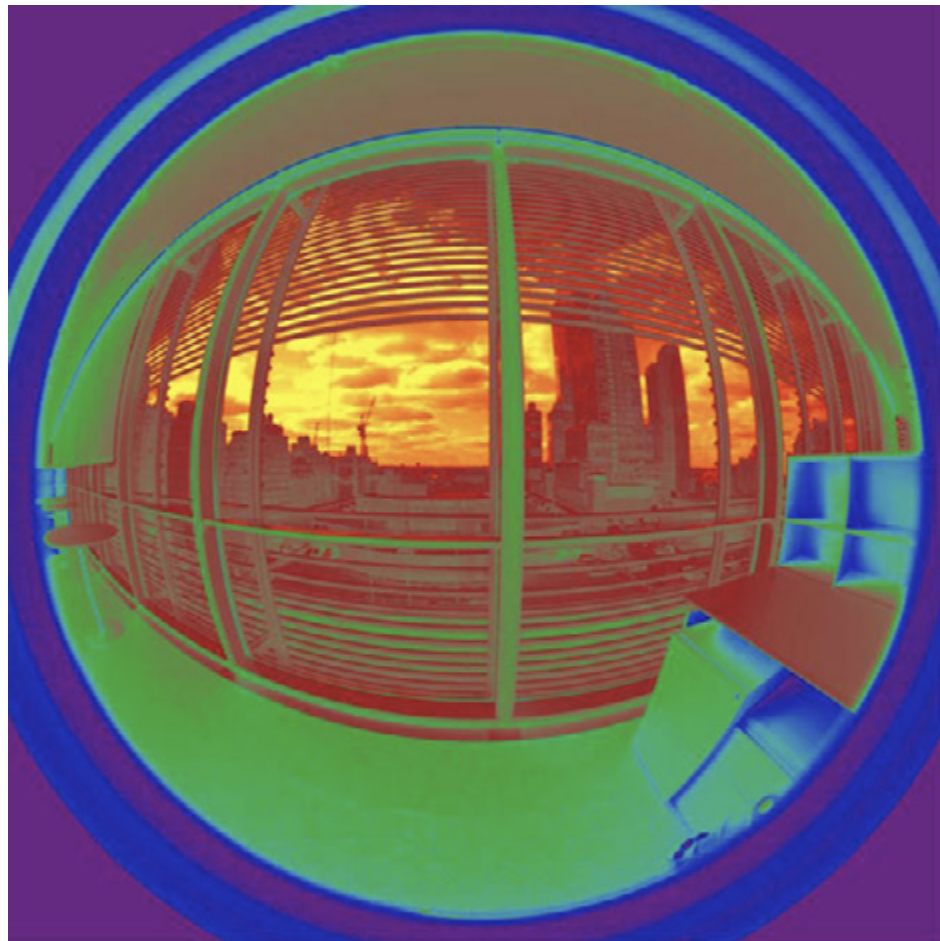

Studio Phase 2: Up Dating the Mock Up

Above: Luminance map produced by the commissioning tool to evaluate average window luminance (shades are in fully raised position in this image). The brighter yellow and red regions have the potential to cause discomfort glare. Notice how the architectural features of the building – the exterior shading system – mitigates glare from the upper, brighter regions of the sky. Copyright: LBNL. Jennifer Blessing



We are designing the new Mock Up: Not an actual office but the means to design/test the office

Above: The view section of the window wall is the open portion between the upper and lower exterior shading elements (photo from the daylighting mock-up at College Point, New York). Copyright: LBNL.



Early 2000's: The Lawrence Berkeley Lab assists Renzo Piano to exceed building codes, improve energy performance, improve optic comfort and LEED. Low Iron Glass and Environmental Controls

The Lawrence Berkeley Labs: The New York Times daylighting design: Low Iron Glass is shaded by 1-5/8" diameter ceramic rods. Automated shading devices and light balancing create an optically comfortable workspace. Video (above) shows mock up testing for daylighting.

The automated shading enabled lighting and cooling energy use reductions, and reductions in peak electric demand. Energy savings due to the shading system alone could not be determined in isolation but the reduction in annual electricity use due to the combination of all three systems was estimated to be 24% (2.58 kWh/ft2-yr) across a typical tower floor compared to a code-compliant building. Annual heating energy use was reduced 51%. Peak electric demand was reduced by 25%. The Times Company's investment in advanced energy-efficiency technologies was estimated to yield a 12% rate of return on their initial investment.

Above: wireless sensors in floor of NY Times office.
Source: Lawrence Berkeley Labs <https://facades.lbl.gov/newyorktimes/nyt-post-occupancy.html>



Daylighting the New York Times Building

The automated shading enabled lighting and cooling energy use reductions, and reductions in peak electric demand. Energy savings due to the shading system alone could not be determined in isolation but the reduction in annual electricity use due to the combination of all three systems was estimated to be 24% (2.58 kWh/ft²-yr) across a typical tower floor compared to a code-compliant building. Annual heating energy use was reduced 51%. Peak electric demand was reduced by 25%. The Times Company's investment in advanced energy-efficiency technologies was estimated to yield a 12% rate of return on their initial investment.

Above: wireless sensors in floor of NY Times office.

Source: Lawrence Berkeley Labs <https://facades.lbl.gov/newyorktimes/nyt-post-occupancy.html>

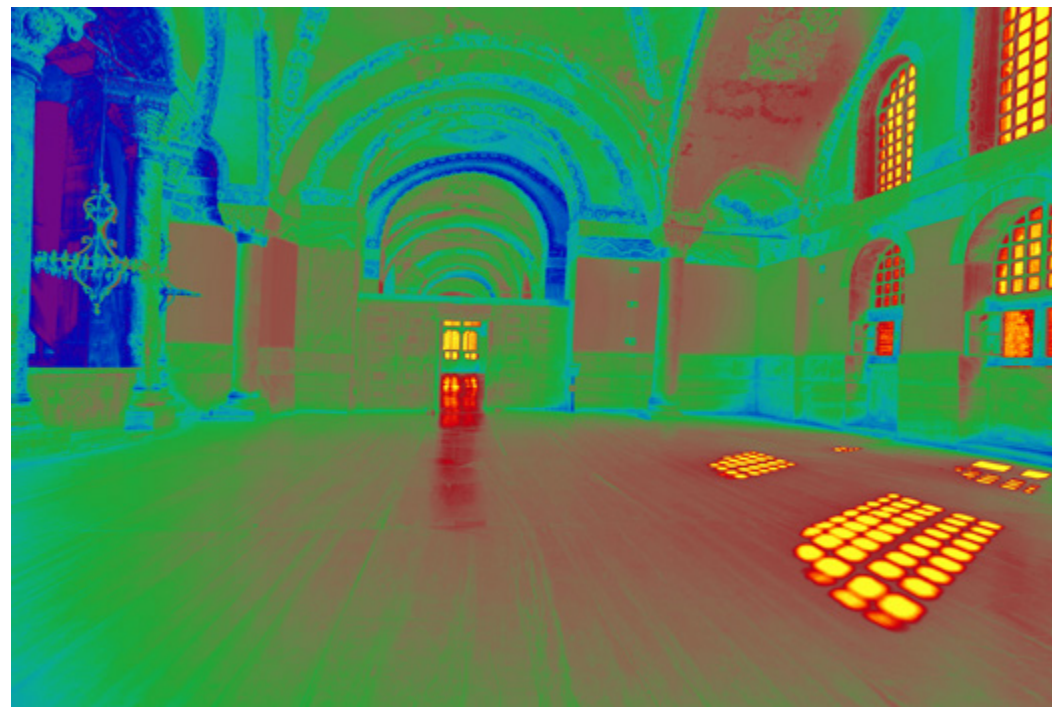

Heat and Light: historical and present day examples. Image 1 and 2: Daylighting and electric lighting analysis of Hagia Sophia using high dynamic range photography technique.

The lighting quality in Hagia Sophia has been a topic of interest for centuries among visitors, writers, poets, and researchers. In fact, almost all literature on Hagia Sophia includes a brief statement on its daylighting and sun-lighting. In these documents lighting is defined as “poetic”, “magical” and “mystical”. Yet, there were not any comprehensive quantitative studies on Hagia Sophia’s lighting. The objectives of this research is:

- 1) To study the interior luminance values, luminance distribution patterns and luminance ratios in Hagia Sophia under naturally occurring sky conditions (the factors that are instrumental for creating the unique luminous environment in Hagia Sophia are discussed).
- 2) To study the electric lighting in conjunction with the daylighting in Hagia Sophia (the impact of electric lighting on the ambient light levels and luminance distribution patterns is evaluated during daylight hours).
- 3) To evaluate the analysis results and to provide recommendations on the lighting scheme of Hagia Sophia (the objective is to preserve the luminous environment as close as possible to the original design, and to improve the visitor experience).

Source: Mehlika Inanici, University of Washington (team member NY Times daylighting and LBL)

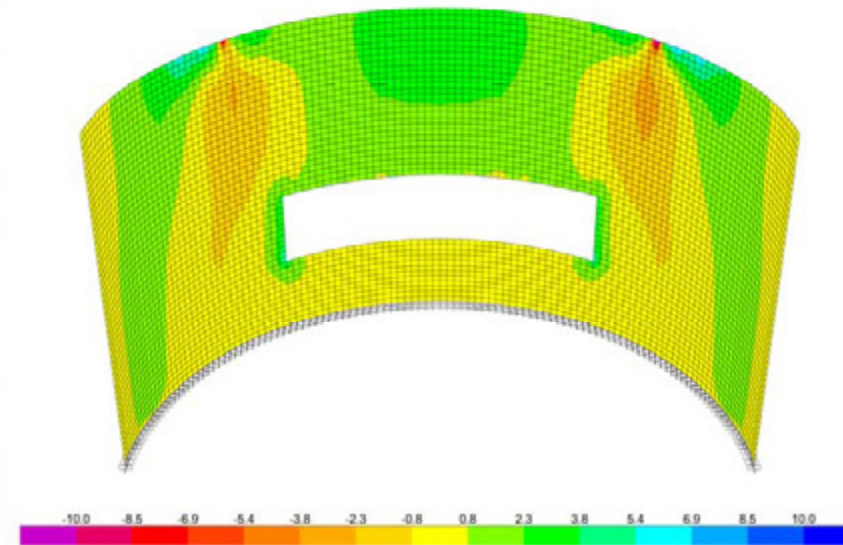
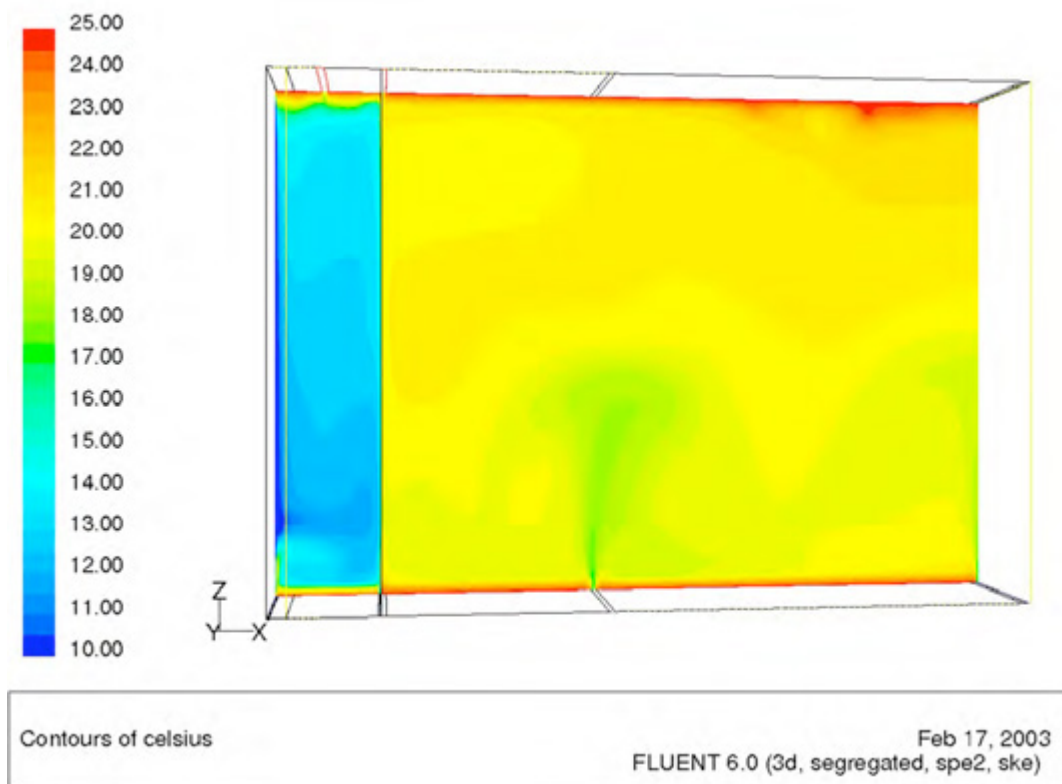
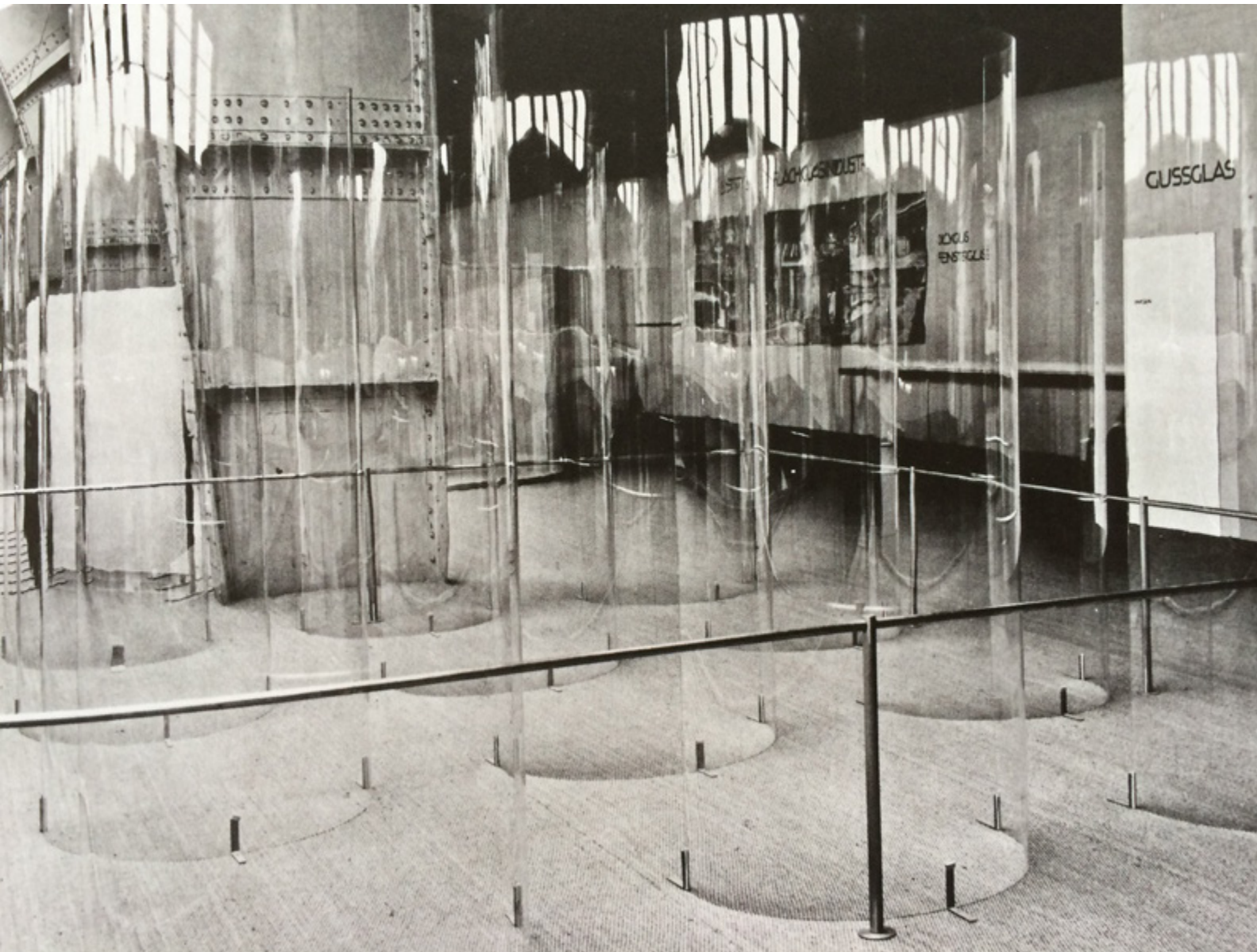

Figure 5 Photograph of Window Inset in Steel Plate Shear Wall in Lampworking Room and Corresponding Finite Element Analysis Model

Matthias Schuler: Transsolar . Guy Nordenson, Structural Engineer: Toledo Glass Pavilion:

A solution with heat supply by radiation through the floor and ceiling surfaces, allows SANAA to temper the facade and buffer heat loss and gain without huge air flow rates. The heat supply by radiation heats the glass surfaces not by the air, but in a direct path. Therefore the air temperature in the cavity can be reduced to 12.5°C and with the only minimal reduced surface resistances, the heat losses through the facade drop to 180 W/m² or by 40%. The inner surface temperatures facing the room keep the level of 15-25°C, out of the condensation range. Aside of the balance method the CFD evaluations confirmed the approach to reduce the air flow rate and instead use the radiant system. By factor four and with strong consequences for the size of the ducts, solving strong conflicts with the structural concept. As a side effect, the radiant heating system can be used in summer as a radiant cooling system, absorbing radiation before it heats the air and has to be removed by an air flow. Source: Engineered Transparency, The Visual, Technical and Spatial Effects of Glass, Edited by Michael Bell and Jeannie Kim.



An Architectural History of Materials
Material's Isolated Qualities in a Commodity Market

Glass Exhibition: Berlin, 1934
 Deutsches Volk, Deutsche Arbeit
 Designed by Lilly Reich and Mies van der Rohe.

Non-Ferrous Metals: Berlin, 1934
 Deutsches Volk, Deutsche Arbeit
 Designed by Walter Gropius

Photograph: Harvard Art Museums/Busch - Reisinger Museum, Gift of Ise Gropius

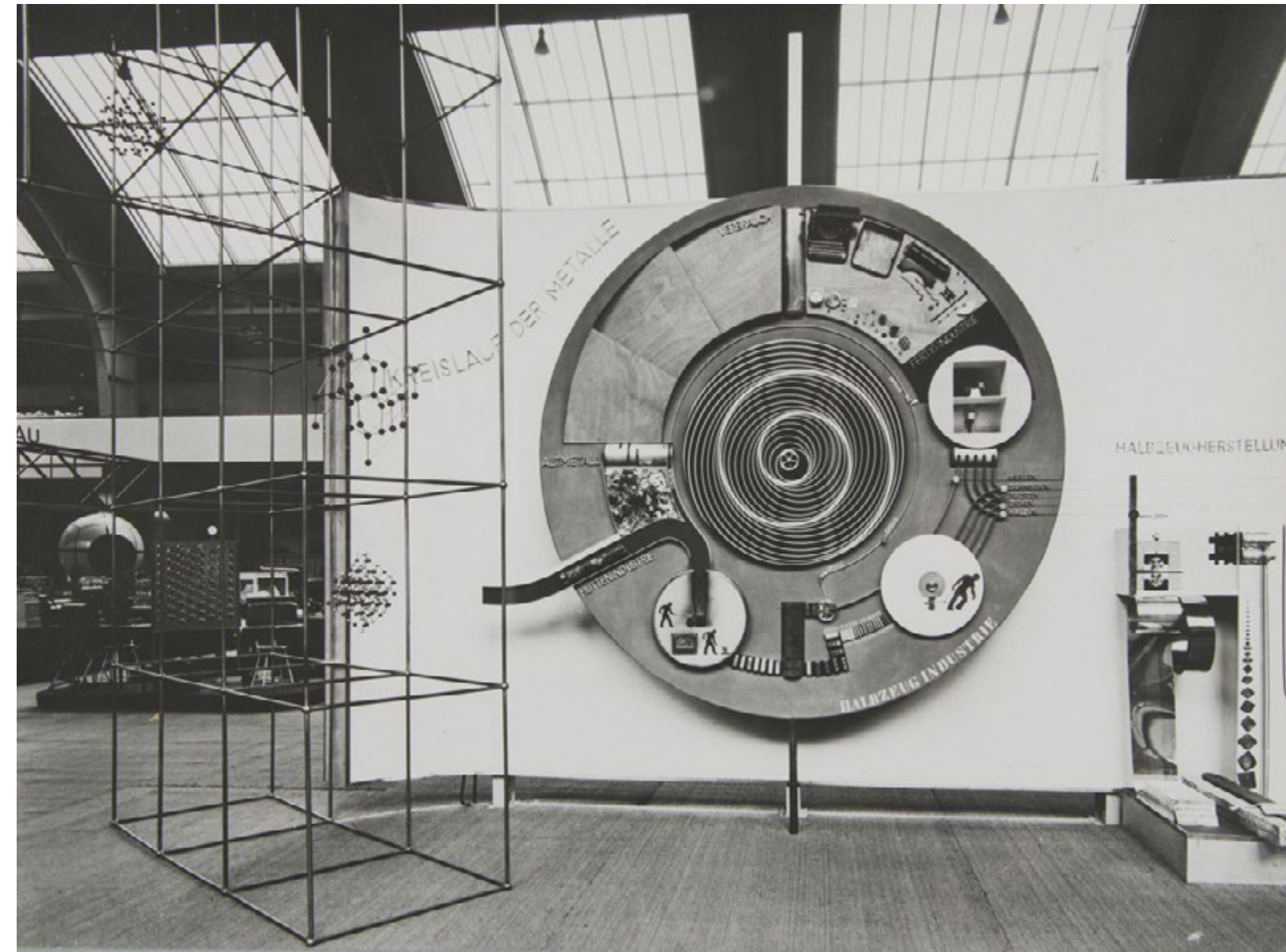

American try to maintain old rituals but the proximity of the machine has both liberated them and made their space uncomfortable. The American's are displaced, lost adjacent to their own means of liberation. They don't yet miss the city. Robert Frank. The Americans.





Creative Observation: Observing the Subject: The Subject Made Opaque

In *Techniques of the Observer* Jonathan Crary provides a dramatically new perspective on the visual culture of the nineteenth century, reassessing problems of both visual modernism and social modernity.

Inverting conventional approaches, Crary considers the problem of visibility not through the study of art works and images, but by analyzing the historical construction of the observer. He insists that the problems of vision are inseparable from the operation of social power and examines how, beginning in the 1820s, the observer became the site of new discourses and practices that situated vision within the body as a physiological event. Alongside the sudden appearance of physiological optics, Crary points out, theories and models of “subjective vision” were developed that gave the observer a new autonomy and productivity while simultaneously allowing new forms of control and standardization of vision.

Crary examines a range of diverse work in philosophy, in the empirical sciences, and in the elements of an emerging mass visual culture. He discusses at length the significance of optical apparatuses such as the stereoscope and of pre-cinematic devices, detailing how they were the product of new physiological knowledge. He also shows how these forms of mass culture, usually labeled as “realist,” were in fact based on abstract models of vision, and he suggests that mimetic or perspectival notions of vision and representation were initially abandoned in the first half of the nineteenth century within a variety of powerful institutions and discourses, well before the modernist painting of the 1870s and 1880s.

Crary: If discourses of the visible in the seventeenth and eighteenth centuries repressed and concealed whatever threatened the transparency of an optical system, Goethe signals a reversal, and instead poses the opacity of the observer as the necessary condition for the appearance of phenomena. Pure light and pure transparency are now beyond the limits of the visible.'

The articulation of subjective vision in the early nineteenth century is part of a shift which Foucault calls “the threshold of our modernity.” When the camera obscura was the dominant model of observation it was as “a form of representation which made knowledge in general possible.” But at the beginning of the nineteenth century the site of analysis is no longer representation but man in his finitude.

... [It was found] that knowledge has anatomo-physiological conditions, that it is formed gradually within the structures of the body, that it may have a privileged place within it, but that its forms cannot be dissociated from its peculiar functioning; in short, that there is a nature of human knowledge that determines its forms and that at the same time can be manifest to it in its own empirical contents.” Michael Foucault

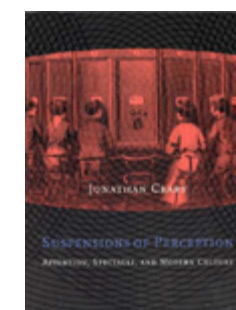
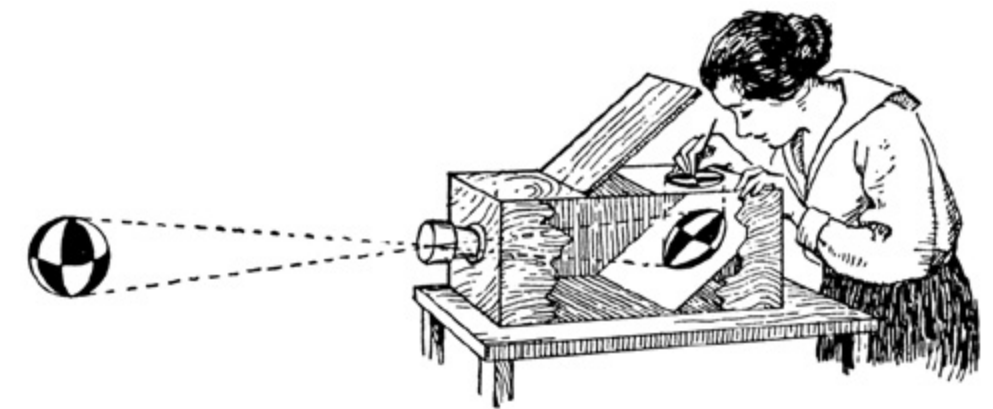

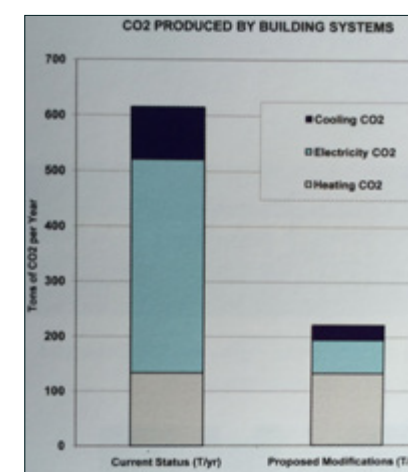
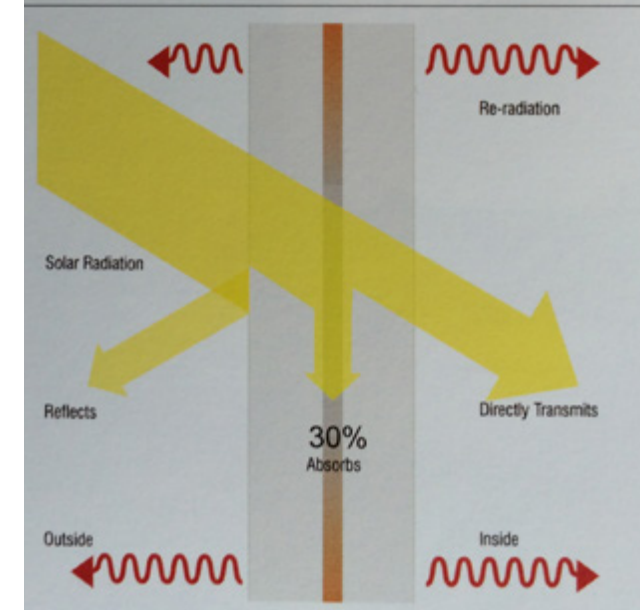
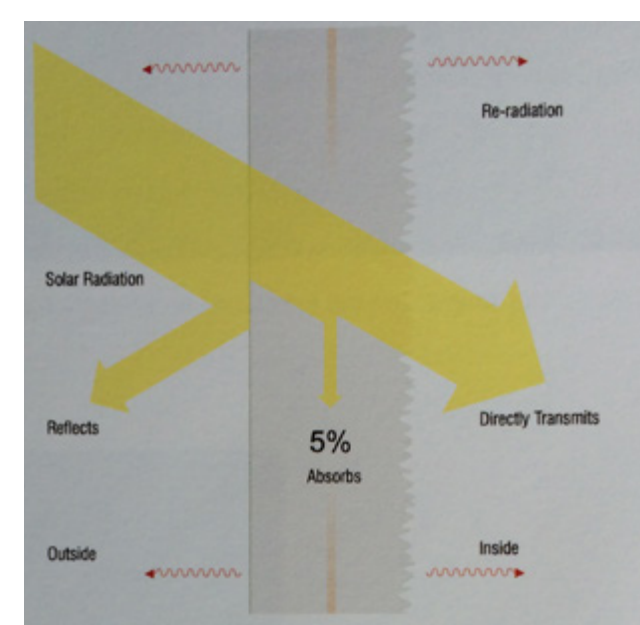

Mark Sexton: 2013: Restoration and Renovation

The lower panes of glass, doubled to each large pane above and milky-white to provide a measure of privacy, presented another problem. Mies's originals had been sandblasted to create a white translucent finish. They were all replaced in 1975 with two eighth-inch panes of glass and a plastic film sandwiched in between. "We went to the laminate because of the breakage and the number of

people that got hurt from it," says Beltemacci, but the result was less translucent than opaque, casting reflections back into the building.

"One of the things that's changed," explains Sexton, "is that there's now federal code that requires all of this glass to either to be laminated or tempered, and at the time in 74 or so you couldn't really temper a piece of sandblasted glass because when you do, you get a very thin layer of tension on the glass, and the

sandblasting, because it was all done by hand, would break through that and it would be prone to breakage, so that wasn't a good condition. When Mies did the original building, this glass was not tempered. It was just annealed. Now by law we have to temper it, but because of advances in sandblasting technologies, it's all done by computer mechanism, and they now take off such a thin layer of glass . . . We went and researched this.

IIT: Transsolar: Matthias Schuler

Source: Engineered Transparency, The Visual, Technical and Spatial Effects of Glass, Edited by Michael Bell and Jeannie Kim

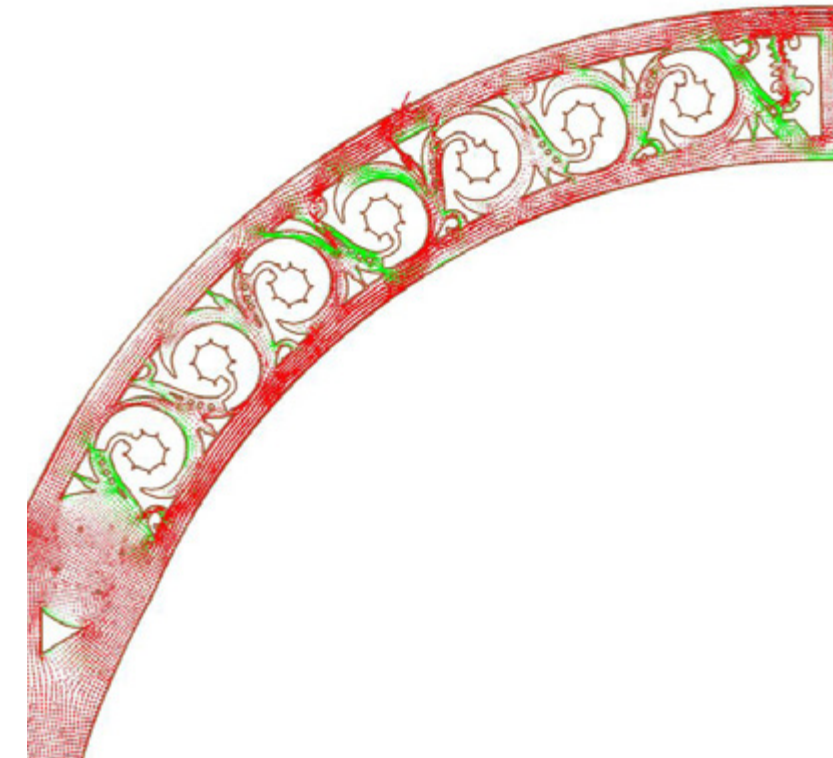
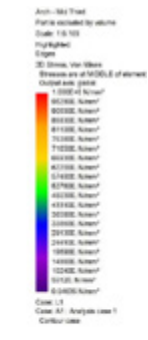
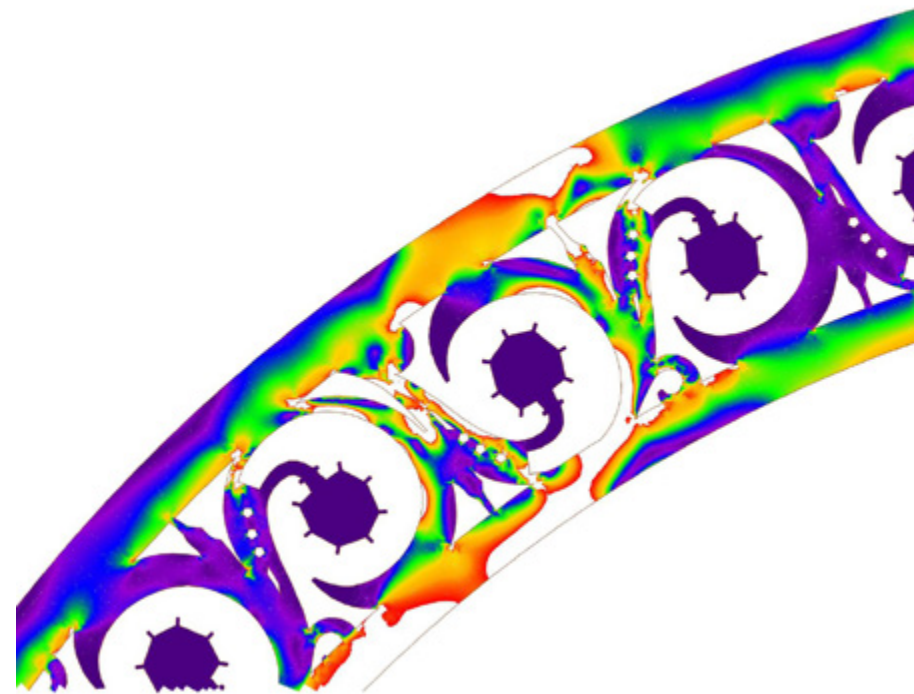
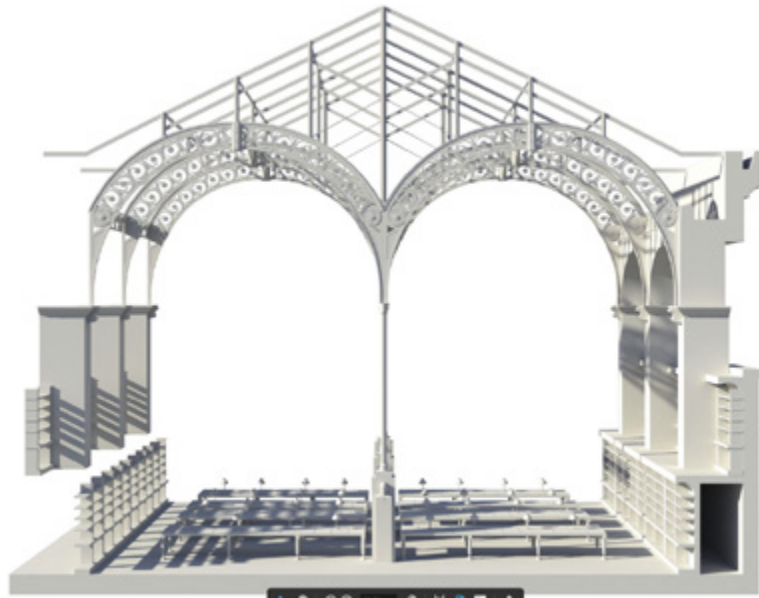

Material in Concert with Structure allow a new Creative Space

Iron and the Ornamental Reduction of Tension at the Bibliothèque Sainte-Geneviève (1838-50)

Henri Labrouste creates an double arch that spans a public reading room. The arch relies on the ornamental leaf pattern's clockwise/counter-clockwise rotation to reduce the presence of tension in the structural iron. A new national reading room, a place of creativity, is established by way of an ancient material and new level of structural control.

Paper by Michael Bell; Study by Michael Bell, Zachary Kostura and presented at the Museum of Modern Art.

