

**The Woodlawn Cemetery:
Mausoleum of Theilmann**

You Wu

Studio I-Historic Preservation

Professor Andrew Dolkart, Claudia Kavenagh, Kimberly Yao

28 September 2018

The Mausoleum for the Theilmann family is located in the Chestnut Hill area in the Woodlawn Cemetery. Since it is at the southwest corner of the intersection between Chestnut Avenue and Spruce Avenue (Figure 1) with good ventilation and enough sunlight, the overall condition of the building is quite acceptable (Figure.2). Due to the



FIGURE.1 AERIAL VIEW WOODLAWN CEMETERY BY JEROME AVENUE GATES. AVERY LIBRARY, DRAWINGS & ARCHIVES, WOODLAWN CEMETERY RECORDS.

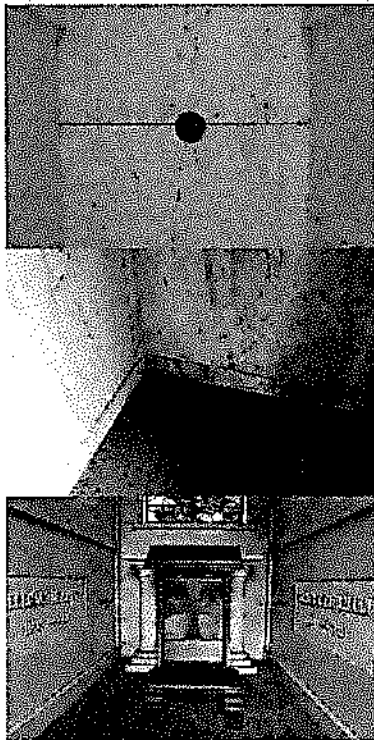

FIGURE.2 DETAILS OF INTERIOR CONDITION, JAMES THEILMANN MAUSOLEUM, WOODLAWN CEMETERY, NEW YORK, U.S., 2018. PHOTOGRAPHED BY YOU WU.

Composite

Columns (Figure.3), which combining the volutes of the Ionic order capital with the acanthus leaves of the Corinthian order and neat design that are similar to the traditional Roman architectural style, it is reasonable to believe that the mausoleum is a Roman Revival Style building. The exterior of the mausoleum is made with light Green's Landing granite, which is

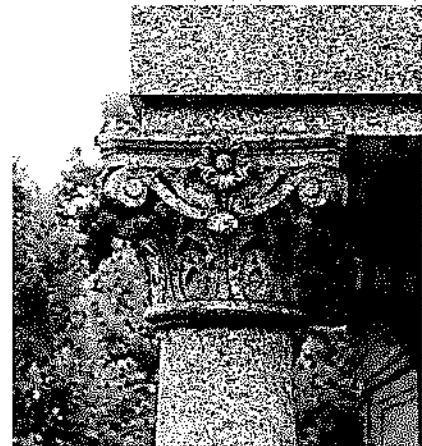

FIGURE.3 COMPOSITE CAPITAL, JAMES THEILMANN MAUSOLEUM, WOODLAWN CEMETERY, NEW YORK, U.S., 2018. PHOTOGRAPHED BY YOU WU.

often used for constructing mausoleum.¹ For both aesthetic and practical reasons, the architect, Daniel S. Goldner, tried to use massive granite blocks so that there are less joints, which might

¹ Request Form. James Theilmann Archive: WCA Major Monuments, Box 17, Folder 66. Avery Library. Classics.

cause leaking problems on each elevation (Figure.4).² Furthermore, there are several components at the exterior that are made by bronze for this building. The door at the entrance is decorated with lion-head handles and square-shaped patterns. There are two bronze ventilation grilles on each side at top of the building; and, a double bronze frame supports



FIGURE.4 OVERALL EXTERIOR CONDITION, JAMES THEILMANN MAUSOLEUM, WOODLAWN CEMETERY, NEW YORK, U.S., 2018. PHOTOGRAPHED BY YOU WU.

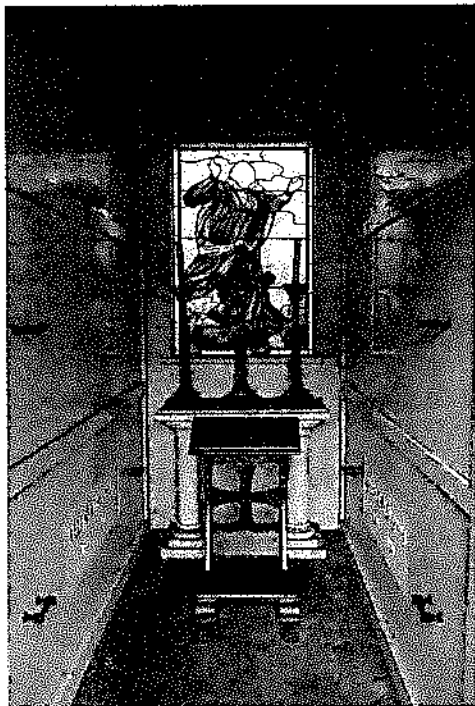

FIGURE.5 INTERIOR OF JAMES THEILMANN MAUSOLEUM, WOODLAWN CEMETERY, NEW YORK, U.S., 2018. PHOTOGRAPHED BY YOU WU.

the stained-glass window with an image of ascension

on it. When observing the interior (Figure.5), it is clear that all walls are lined with Italian marbles³, which are highly polished. Other than that, six catacombs are all made with slates for shelves and tablets.⁴ They are later replaced by Smooth Sound Pennsylvania Stock and new Italian English Veined Marble for alteration.⁵ Bronze handles on each catacomb and a Bronze Lewis Hanger⁶ inserted in the granite roof stone to support the marble ceiling are also bronze components within the building.

By using rubble as the material for the foundation, the interior floor is unified with exterior

² Specifications. James Theilmann Archive: WCA Major Monuments, Drawer 4.1, Folder 68. Avery Library. Classics.

³ Ibid

⁴ Ibid

⁵ Ibid

⁶ Ibid

material, which is unpolished granite.⁷

Based on the documents and actual situation of the mausoleum, it is clear that there are two catacombs inside the mausoleum in use. One is for James T. Theilmann, who is the head of the family. He was born in Germany at July 1841 and immigrated to America at around 1870. Once he came to America, he started his career as a merchant and then at 1873 became an employee at Delmonico's Restaurant, which was then located at the corner of Fifth Avenue and 26th Street (Figure.6).

Delmonico's is the first dining place called a "restaurant" in America.⁸ Before that, dining places were called "cafés" or other names. Moreover, there are many other first establishments at Delmonico's: - The first restaurant to have a "star" chef, the first restaurant to have a female cashier, and so on. There are several changes



FIGURE.6 CAFE MARTIN (OLD DELMONICO'S), NEW YORK. THE NEW YORK PUBLIC LIBRARY DIGITAL COLLECTIONS. 1908.

during the history of Delmonico's. Specific to the working period and location of James Theilmann, the restaurant that is under his management is not headquarters, but one of the branches at the time. "Then the restaurant was moved to 212 26th Street, corner of Fifth Avenue and 26th Street, near Madison Square (11 September 1876 to 1899.) Housed in what had been the Dodsworth Studio Building (where a young Teddy Roosevelt had taken dancing lessons.) When Delmonico's abandoned the building in 1899, it became the "Cafe Martin." The

⁷ Specifications. James Theilmann Archive; WCA Major Monuments, Drawer 4.1, Folder 68. Avery Library. Classics.

⁸ Choate, Judith, and James Canora. Dining at Delmonico's: the Story of America's Oldest Restaurant. Stewart, Tabori & Chang, 2008.

building was demolished a few years later and replaced with a new one in 1913.⁹ During the time working at Delmonico's, he took his steps to be the manager of the restaurant, following the directions of Charles Delmonico, the nephew of John Delmonico, the founder of the restaurant.

There used to be a robbery happened during Theilmann's career. Two thieves robbed the wagon when the driver finished loading most goods and went back to pick up rest champagnes. Fortunately, there was another driver that happened to meet the missing wagon and got things back. However, because of inappropriate storage, there are only four out of fifteen cases of Champagne that survived. Moreover, James Theilmann was mentioned as "phlegmatic Teuton" in the case, because he failed to turn the thief over to the detective for some inexplicable reasons.¹⁰

In 1899, based on business needs, Delmonico's abandoned the building that James Theilmann worked at. Started from there, James Theilmann accepted the suggestions from previous guests who were working at stock exchange near the restaurant and operated in real estate. He passed away on Oct. 9th, 1909 and was buried at 3:30 pm.¹¹ After his death, his wife and daughter inherited around \$500,000, and a bond of \$1,000,000.¹²

Another in-use catacomb is for James Theilmann's wife, Ellen J. Theilmann. She was born in New York at May 1859. Her family immigrated from Ireland. After James

⁹ "Delmonico's Restaurant." CooksInfo.com. Accessed September 28, 2018. <https://www.cooksinfo.com/delmonicos-restaurant>.

¹⁰ "Delmonico Robbed." New York Times (1857-1922), Aug 14, 1889, pp. 5. ProQuest, <http://ezproxy.cul.columbia.edu/login?url=https://search-proquest-com.ezproxy.cul.columbia.edu/docview/94734069?accountid=10226>.

¹¹ "Obituary 1 -- no Title." New York Times (1857-1922), Oct 11, 1909, pp. 9. ProQuest, <http://ezproxy.cul.columbia.edu/login?url=https://search-proquest-com.ezproxy.cul.columbia.edu/docview/96931894?accountid=10226>.

¹² "Fortune Found On Tips." New - York Tribune (1900-1910), Nov 11, 1909, pp. 3. ProQuest, <http://ezproxy.cul.columbia.edu/login?url=https://search-proquest-com.ezproxy.cul.columbia.edu/docview/572305064?accountid=10226>.

Theilmann's death, she signed a contract with Daniel S. Goldner to build the mausoleum in 1910. After five years when the mausoleum finished, Ellen Theilmann was also buried inside the building.

The Theilmann couple only have one daughter, Ellie J. C. Theilmann. She married Sydney A. Williams who signed another contract with Robert Caterson Inc. twenty-four years later for alteration and reconstruction of six catacombs in the mausoleum. Supported by the endorsement James Theilmann left, the mausoleum is in great condition centuries later, for people to memorialize the family now and in the future.

References

Request Form. James Theilmann Archive: WCA Major Monuments, Box 17, Folder 66. Avery Library. Classics.

Specifications. James Theilmann Archive: WCA Major Monuments, Drawer 4.1, Folder 68. Avery Library. Classics.

Choate, Judith, and James Canora. *Dining at Delmonicos: the Story of Americas Oldest Restaurant*. Stewart, Tabori & Chang, 2008.

"Delmonico's Restaurant." CooksInfo.com. Accessed September 28, 2018. <https://www.cooksinfo.com/delmonicos-restaurant>.

Art and Picture Collection, The New York Public Library. "Cafe Martin (Old Delmonico'S), New York." *The New York Public Library Digital Collections*. 1908. <http://digitalcollections.nypl.org/items/510d47e1-2804-a3d9-e040-e00a18064a99>

"DELMONICO ROBBED." *New York Times (1857-1922)*, Aug 14, 1889, pp. 5. *ProQuest*, <http://ezproxy.cul.columbia.edu/login?url=https://search-proquest-com.ezproxy.cul.columbia.edu/docview/94734069?accountid=10226>.

"Obituary 1 -- no Title." *New York Times (1857-1922)*, Oct 11, 1909, pp. 9. *ProQuest*, <http://ezproxy.cul.columbia.edu/login?url=https://search-proquest-com.ezproxy.cul.columbia.edu/docview/96931894?accountid=10226>.

"FORTUNE FOUNDED ON TIPS." *New - York Tribune (1900-1910)*, Nov 11, 1909, pp. 3. *ProQuest*, <http://ezproxy.cul.columbia.edu/login?url=https://search-proquest-com.ezproxy.cul.columbia.edu/docview/572305064?accountid=10226>.

FALL 2018 HISTORIC PRESERVATION STUDIO
FACULTY: ANDREW DOLKART, KIM YAO & CLAUDIA KAVENAGH
WOODLAWN CEMETERY: JAMES THEILMANN
YOU WU
SEPTEMBER 28, 2018

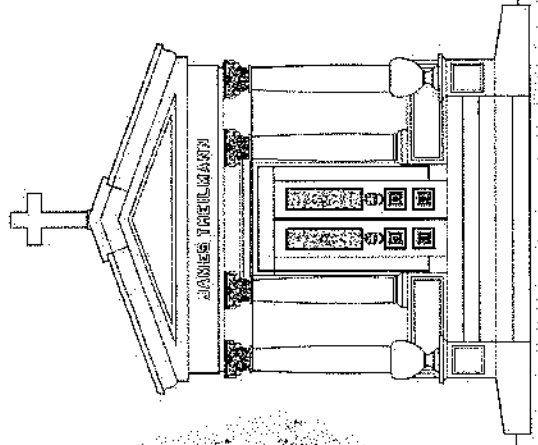

FRONT ELEVATION



FALL 2018 HISTORIC PRESERVATION STUDIO
FACULTY: ANDREW DOLKART, KIM YAO & CLAUDIA KAVENAGH
WOODLAWN CEMETERY: JAMES THEILMANN
YOU WU
SEPTEMBER 28, 2018

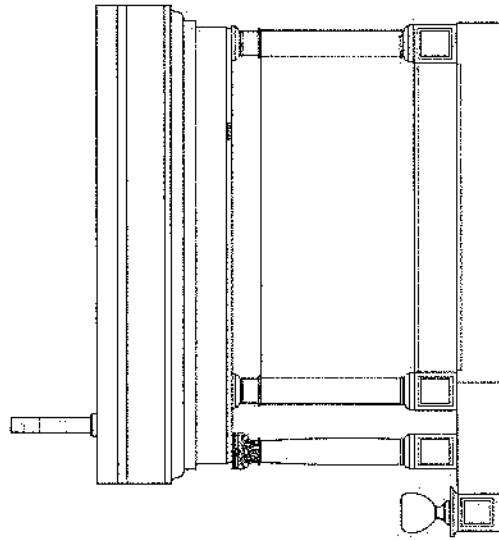

EAST-SIDE ELEVATION

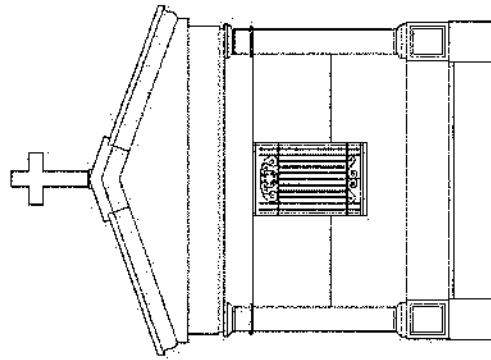

REAR ELEVATION

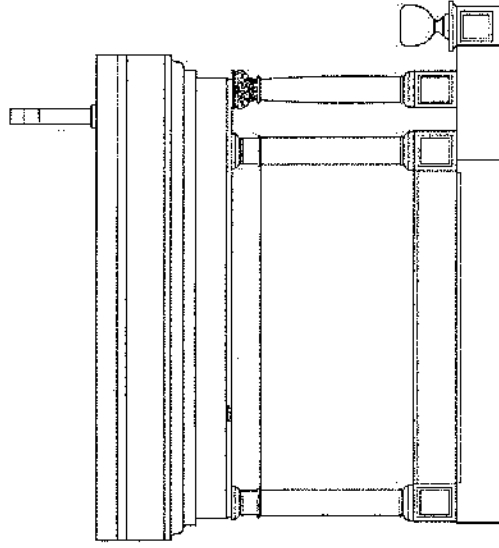

WEST-SIDE ELEVATION



FALL 2018 HISTORIC PRESERVATION STUDIO
FACULTY: ANDREW DOLKART, KIM YAO & CLAUDIA KAVENAGH
WOODLAWN CEMETERY: JAMES THEILMANN
YOU WU
SEPTEMBER 28, 2018

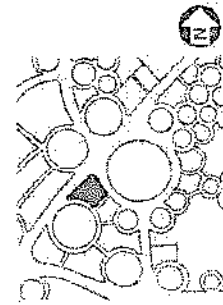
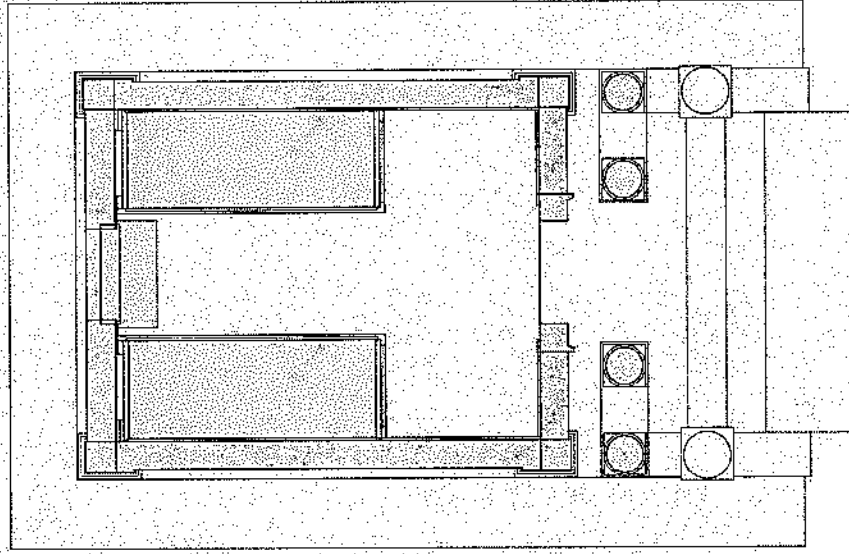

PLAN

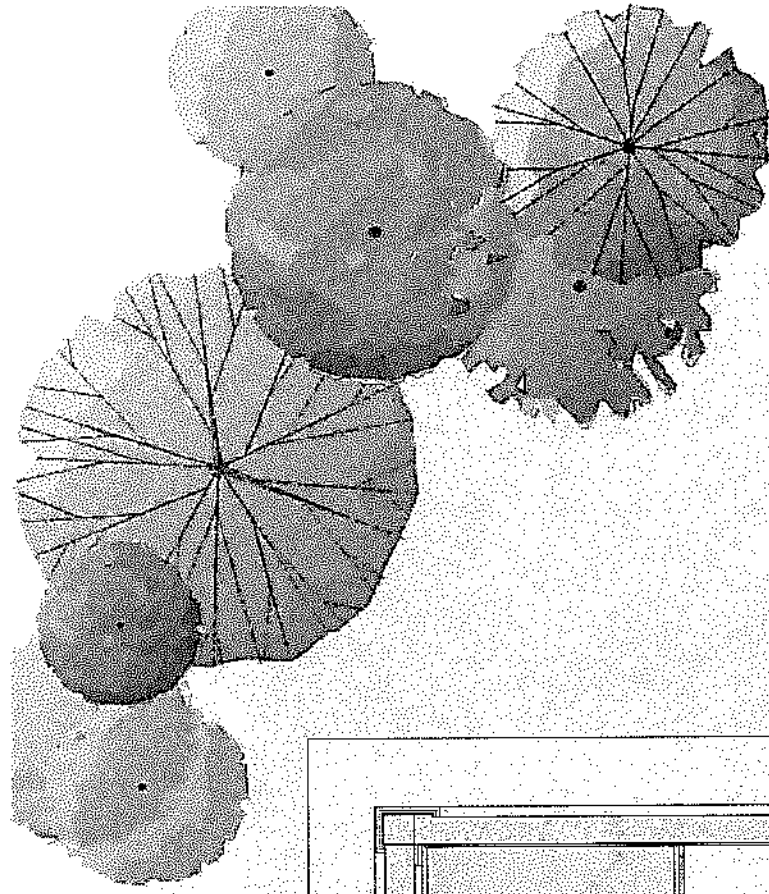

FALL 2018 HISTORIC PRESERVATION STUDIO
 FACULTY: ANDREW DOLKART, KIM YAO & CLAUDIA KAVENAGH
 WOODLAWN CEMETERY: JAMES THEILMANN
 YOU WU
 SEPTEMBER 28, 2018

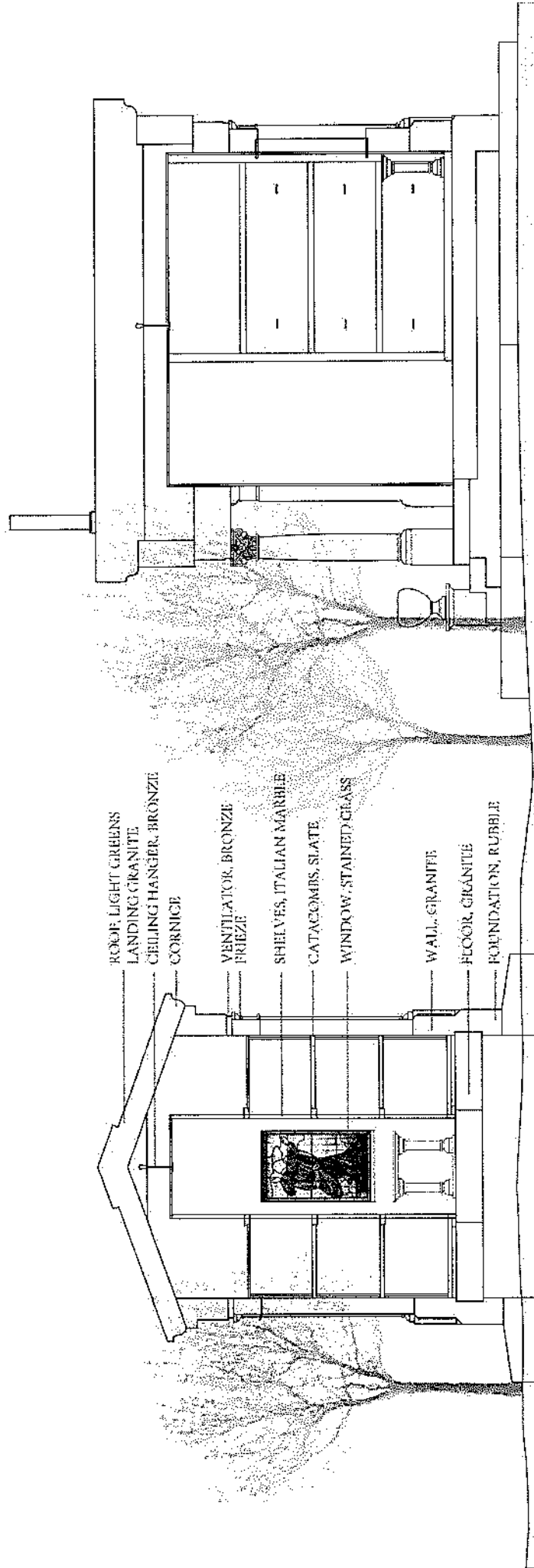

LONGITUDINAL SECTION

CROSS SECTION



FALL 2018 HISTORIC PRESERVATION STUDIO
 FACULTY: ANDREW DOLKART, KIM YAO & CLAUDIA KAVENAGH
 WOODLAWN CEMETERY: JAMES THEILMANN
 YOU WU
 SEPTEMBER 28, 2018



INTERIOR: CATACOMB HANDLE



FRONT ELEVATION: LION-HEAD ON-HEAD HANDLE

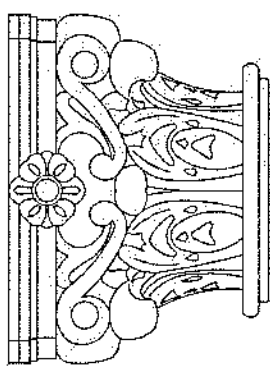

FRONT ELEVATION: COMPOSITE CAPITAL

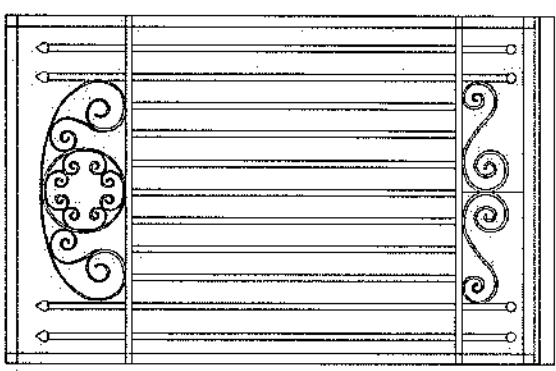

REAR ELEVATION: BRONZE WINDOW FRAME

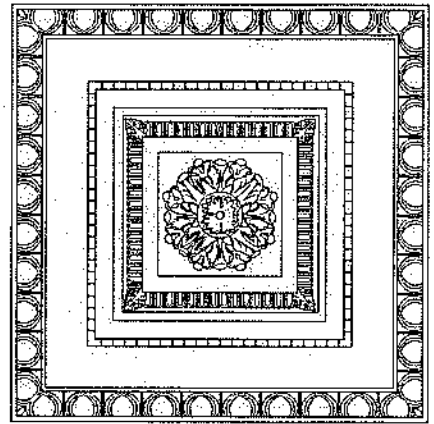

FRONT ELEVATION: DOOR PATTERN

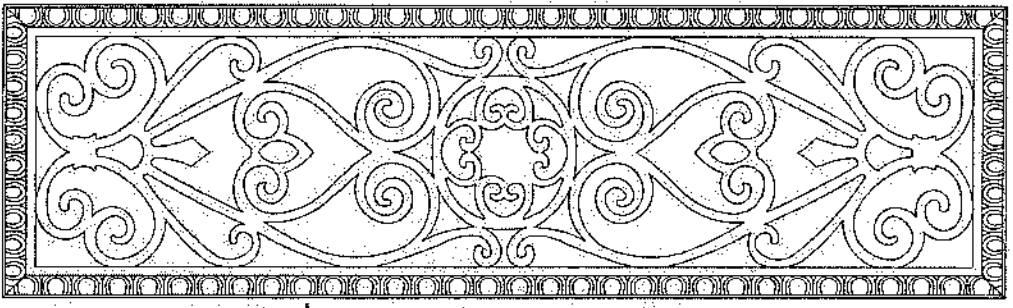
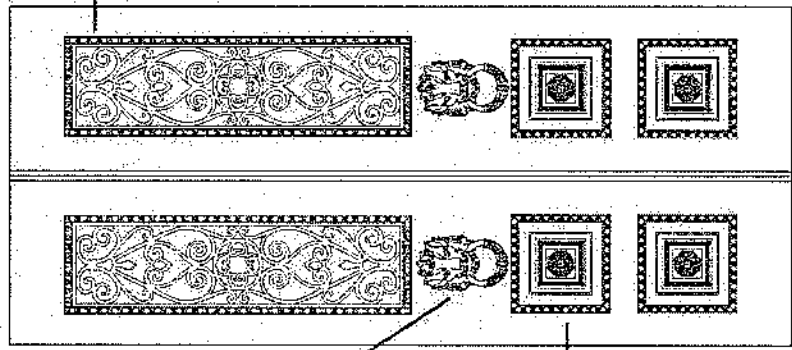

FRONT ELEVATION: DOOR WINDOW PATTERN