

The Queen of Hearts embodies love, tenderness, and care—a symbol that resonates deeply with me.

Throughout my journey at GSAPP, my approach has remained rooted in care.

From the smallest bolt in a wall to the lines on a page, the conceptual framework of each project, I prioritize care. It's the cornerstone upon which I build, centering people, places, and narratives.

In every endeavor I play the card, Queen of Hearts, infusing my work with compassion, playfulness, and empathy.

This portfolio is a collection of projects, methods, and inquiries practicing care.

Playing cards with my dad on a lazy Saturday afternoon, I struggled with the shuffle, while my dad patiently attempted to teach me.

"You just need to keep practicing until your hands catch up," he'd encourage.

So I practiced, in the car, at home, every hour, every day.

Careful practice became natural to me.

Then, one day, my hands had grown.

Care ;

"Caring is a species activity that includes everything that we do to maintain, continue, and repair our 'world' so that we can live in it as well as possible. That world includes our bodies, our selves, and our environment, all of which we seek to interweave in a complex, life sustaining web."

"Care is both a practice and a disposition."

- Moral Boundaries, A Political Argument for an Ethic of Care, Joan C. Tronto

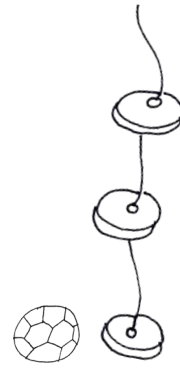
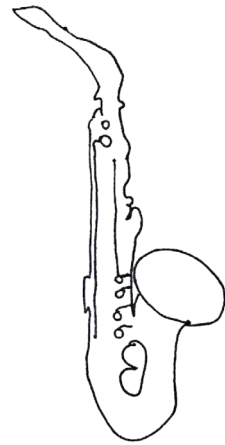
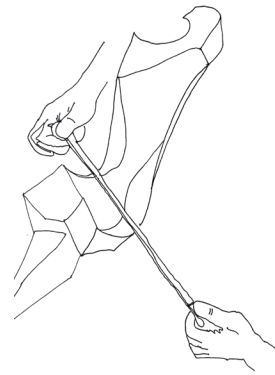
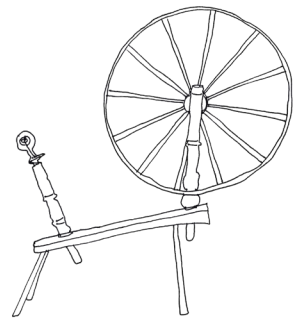

Index

Columbia University

care for

7 Between The Stitches.....*memory*
Advanced IV

31 Leveraging Craft.....*cultural practices*
Advanced V

55 Breathing Liberation.....*restitution*
Advanced VI

77 Harlem Pulse.....*expression*
Core I
Visual Studies Elective - Power Tools

93 XYZ School.....*exploration*
Core II

103 Tectonics of Play.....*detail*
Tech Sequence III-V

113 Under One Roof.....*reclamation*
Core III
Tech Elective - Seed Bombs

*01**Between
The
Stitches*

Memorial / Transitional
Housing
79 E Market St, Hyde Park, NY

Professor
Nina Cooke John

Advanced IV
Spring 2023

On this historical site where a free black community once provided safety and a transitional safe space for those seeking freedom, the project does the same by providing transitional housing for young adults of Poughkeepsie in which it addresses the hierarchy of needs through craft and the act of making as a form of empowerment and a device of memory

The memorial is the site of Primus Martin's house, a well known member of his community. To mark significance, the site of Primus Martin's house is carved out to expose the foundations in contrast to the lifted pathways connecting to it. Through this the goal is to memorialize the individuals of the community that once lived and prospered on this site, but also represent the larger group of freedom seekers who displayed bravery and courage to breakaway from slavery. Fredonia Lane is the main through-way of the memorial calling back to its historical context as the main road for the new guinea community that preceded. A wood structure intersects coplanar with Fredonia Lane and extends outward over the landscape, stitching together the memorial and the transitional housing.

Between The Stitches focuses on making and craft as a form of empowerment and a device of memory.

The quilt was used as a symbol of resistance stitching codes within the fabric to signal the direction to safety, similar to Ashley's Sac, within just the stitching and fabric, an embedded meaning of love, care, and strength are coded within.

Objects become bearers of memory and information, like how the fragments of pottery have done at the primus martin site. However, because of the vulnerability of fabric and its ability to deteriorate, it's often the last material historians look to in order to understand the past.

The ability to be lost within history almost strengthens its ability to store memory. As the author Tiya Miles beautifully articulates "The past seems to reach out to us through these fabrics and the practices of making them that have survived over time."

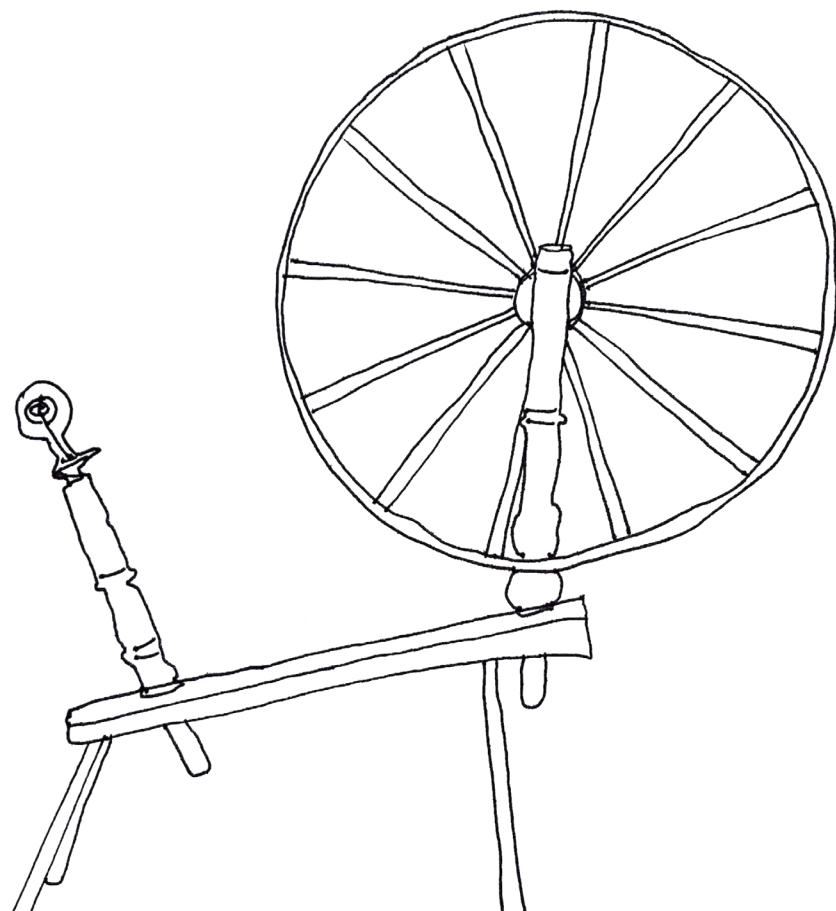



a



b

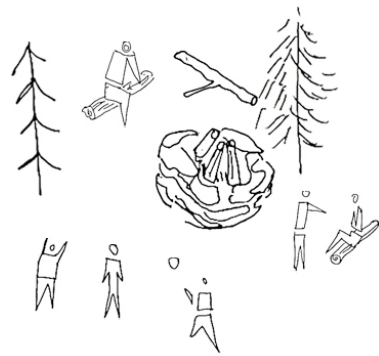
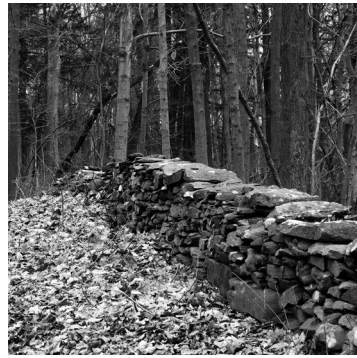

c



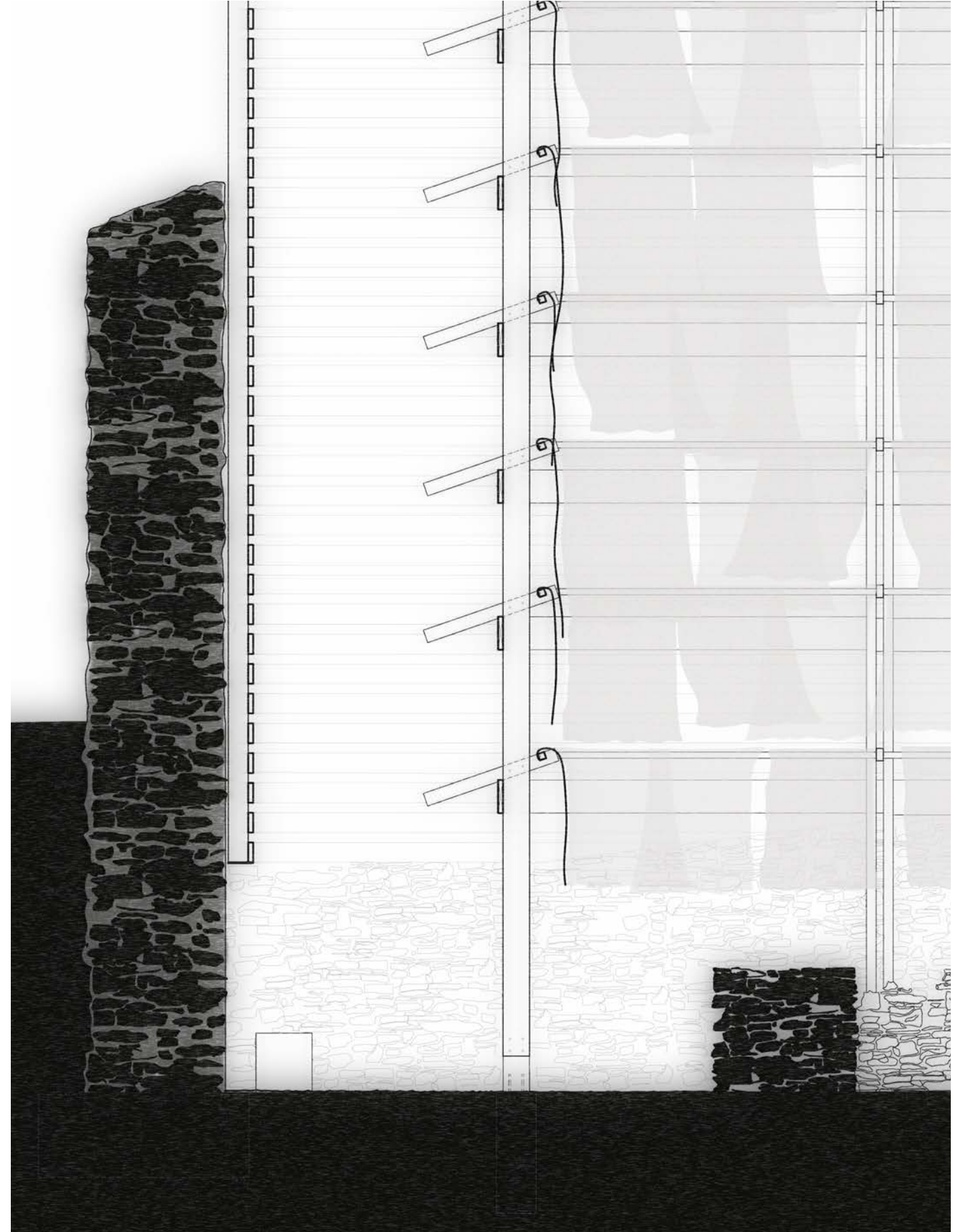
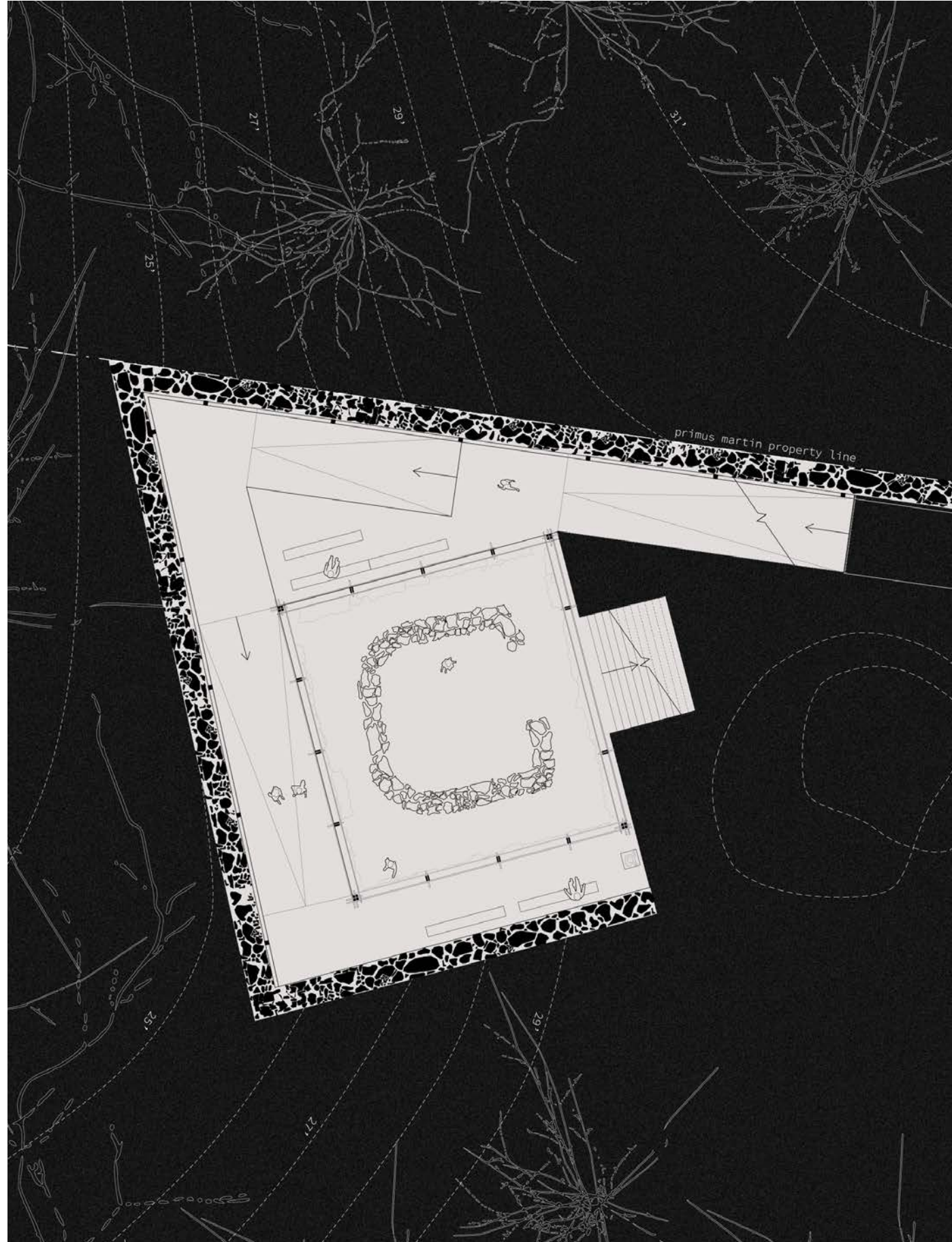

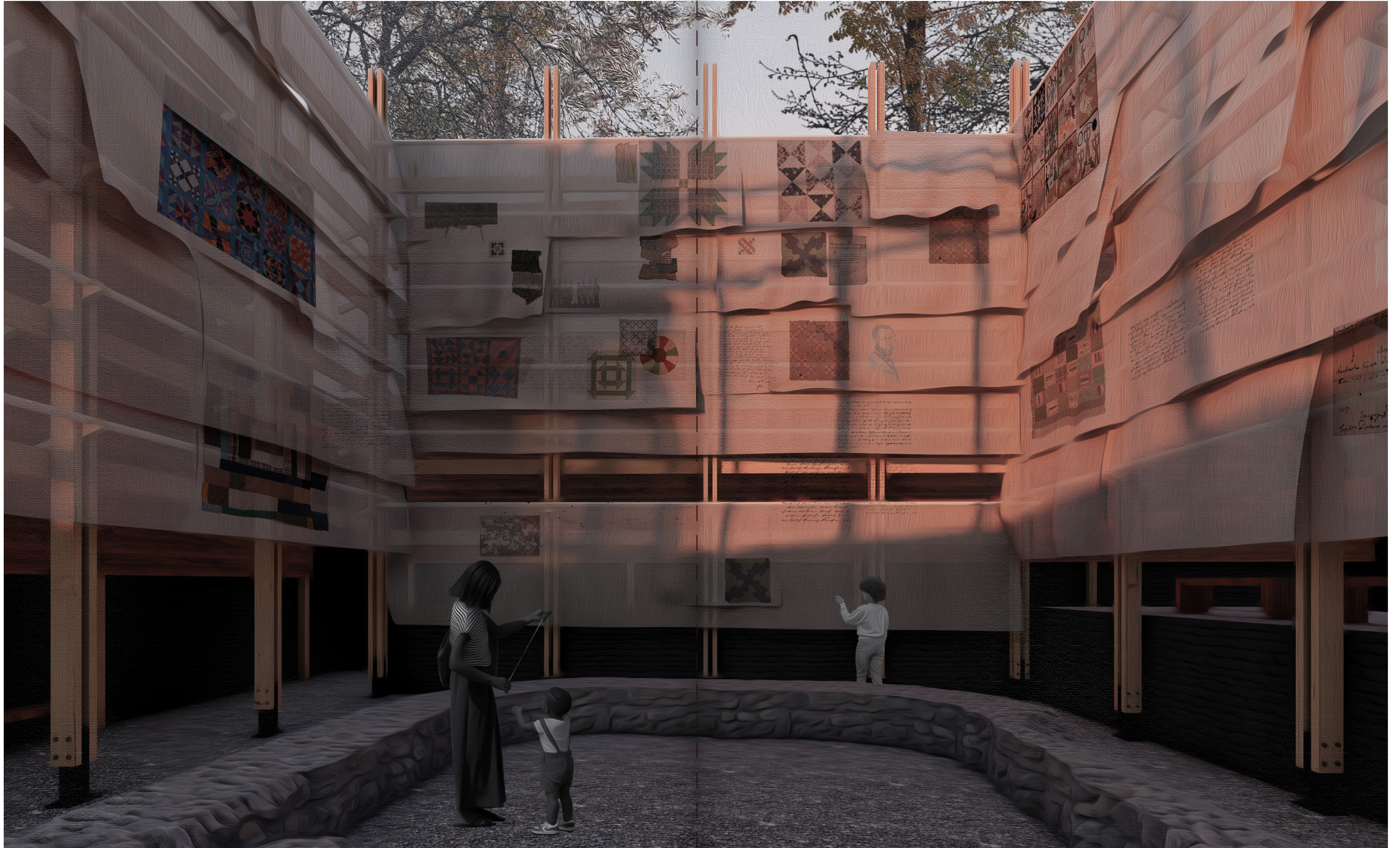

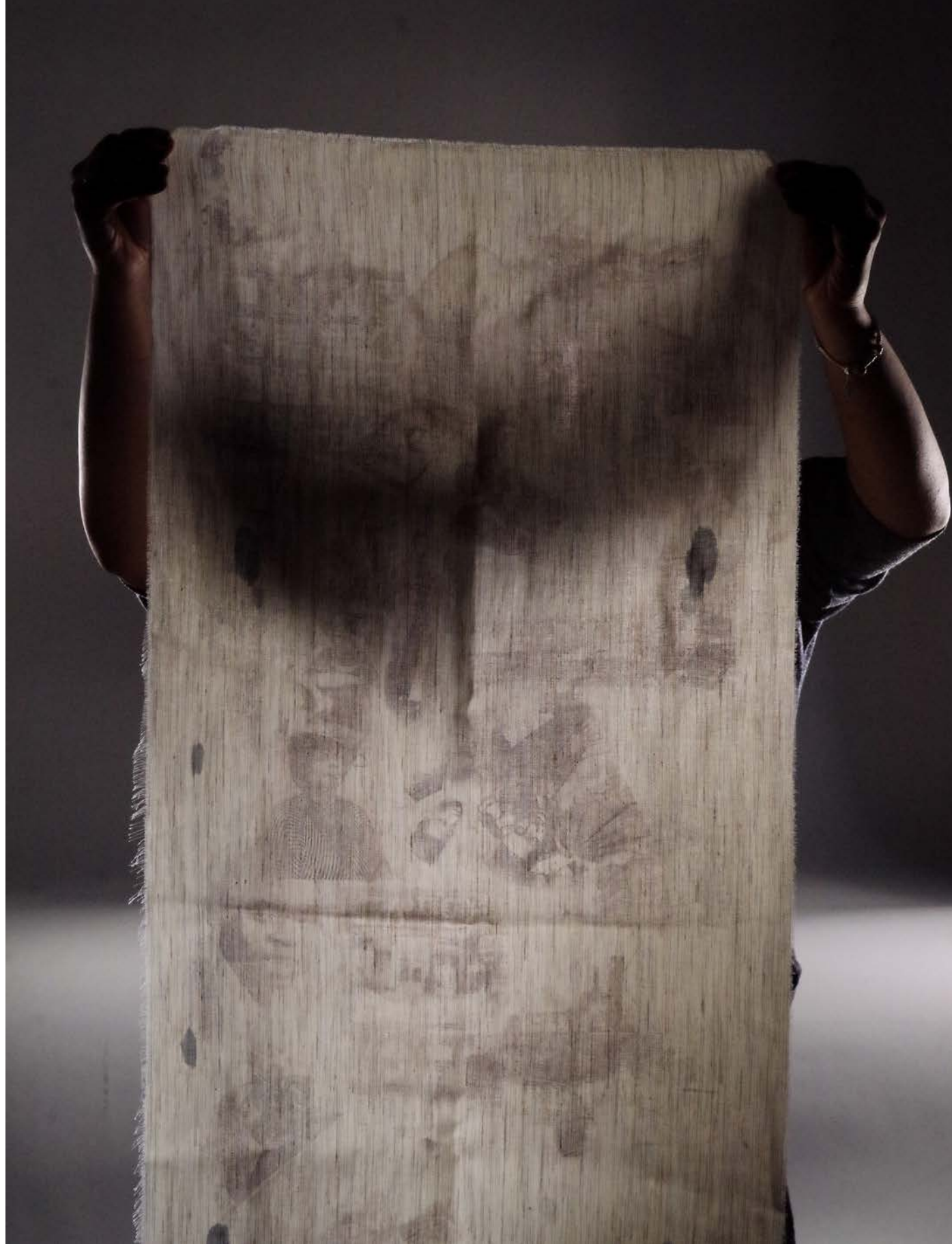

memorial model

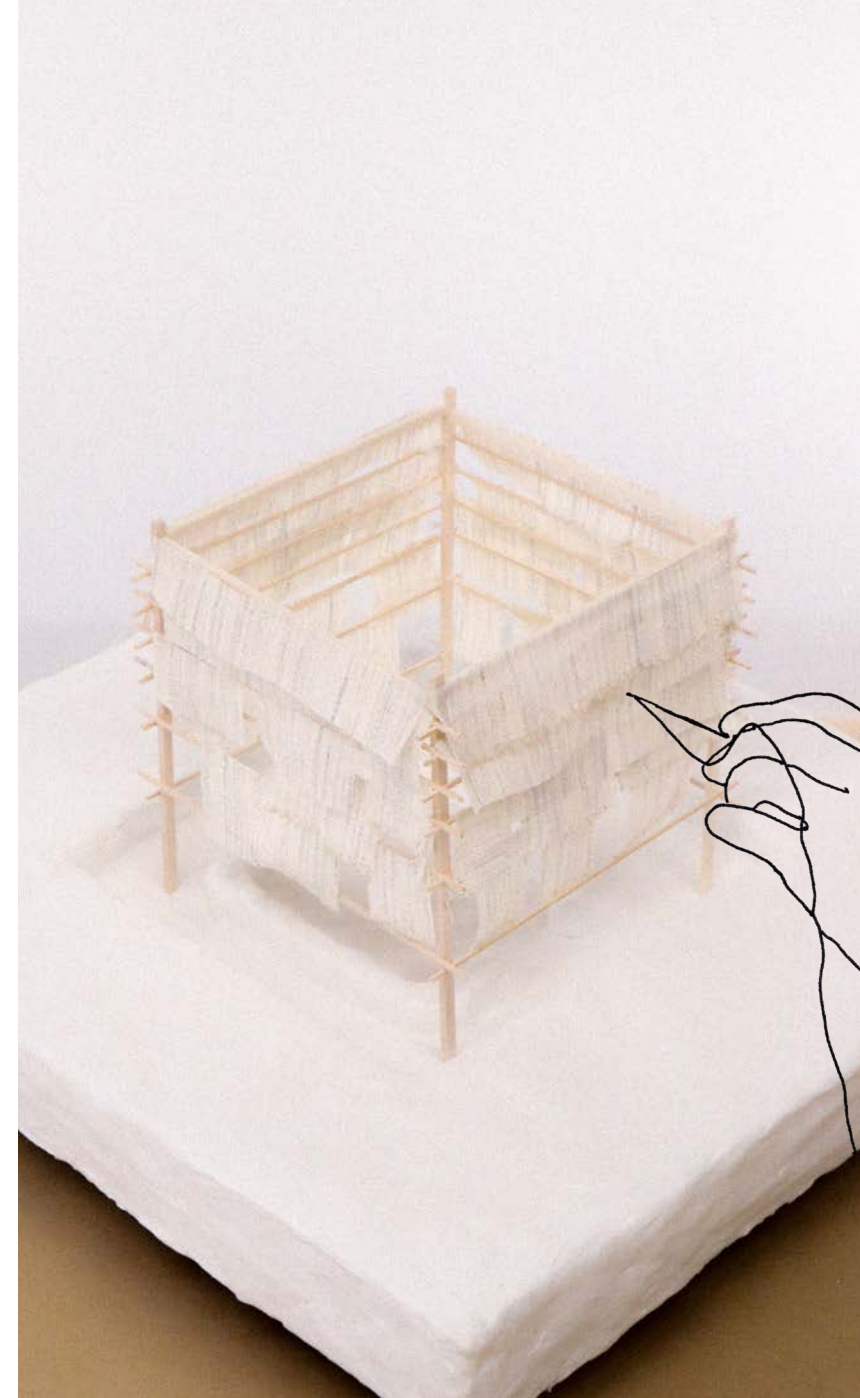

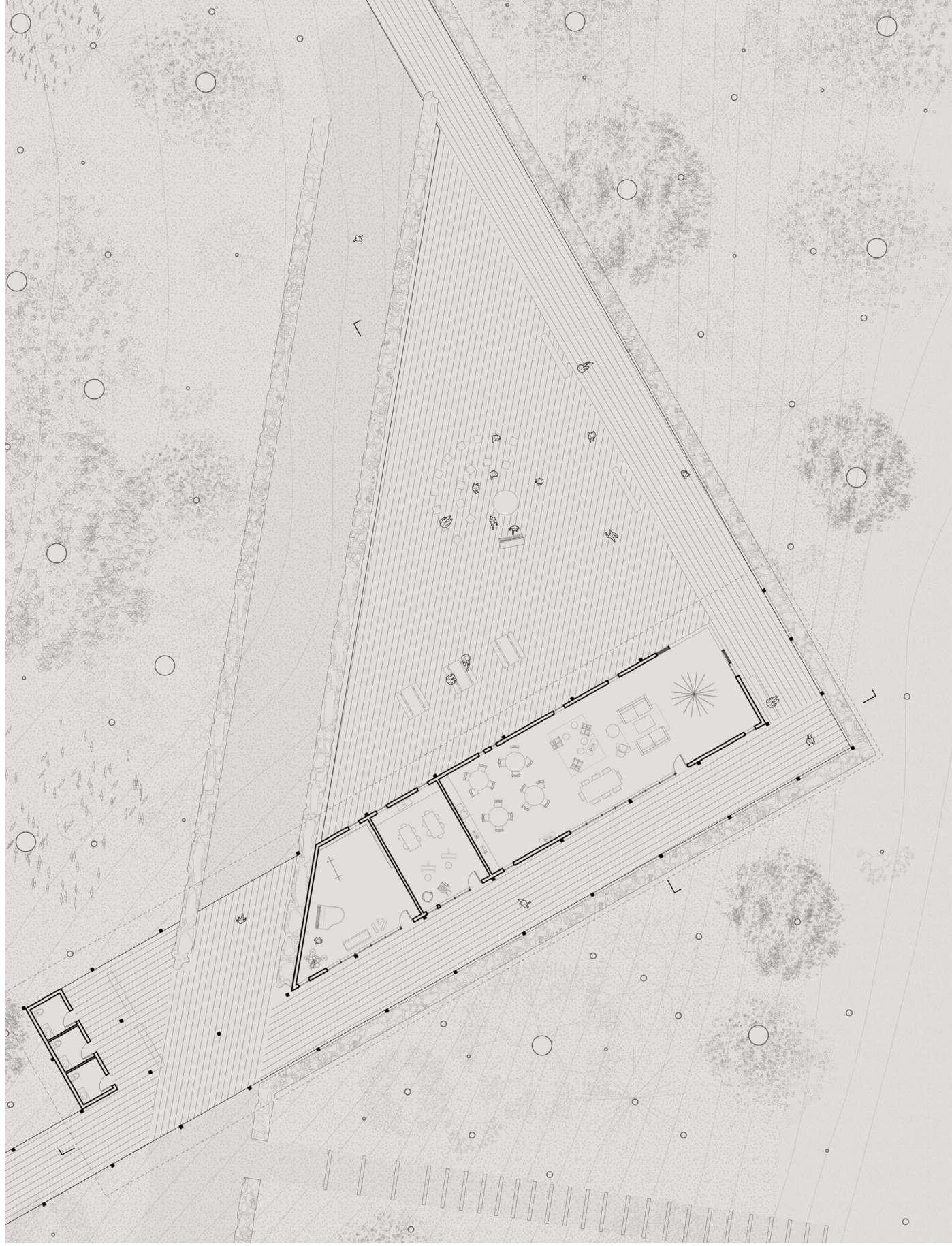

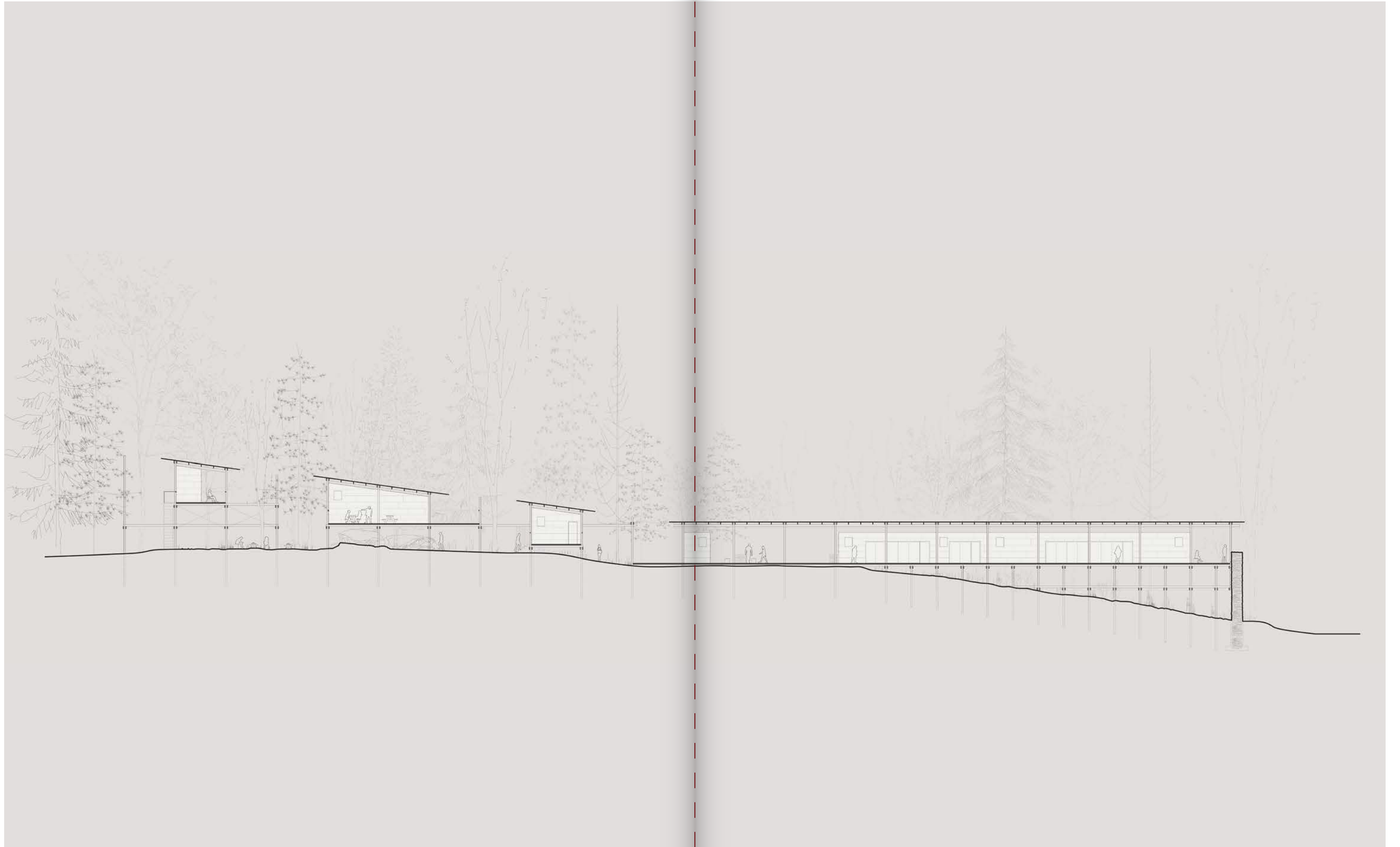



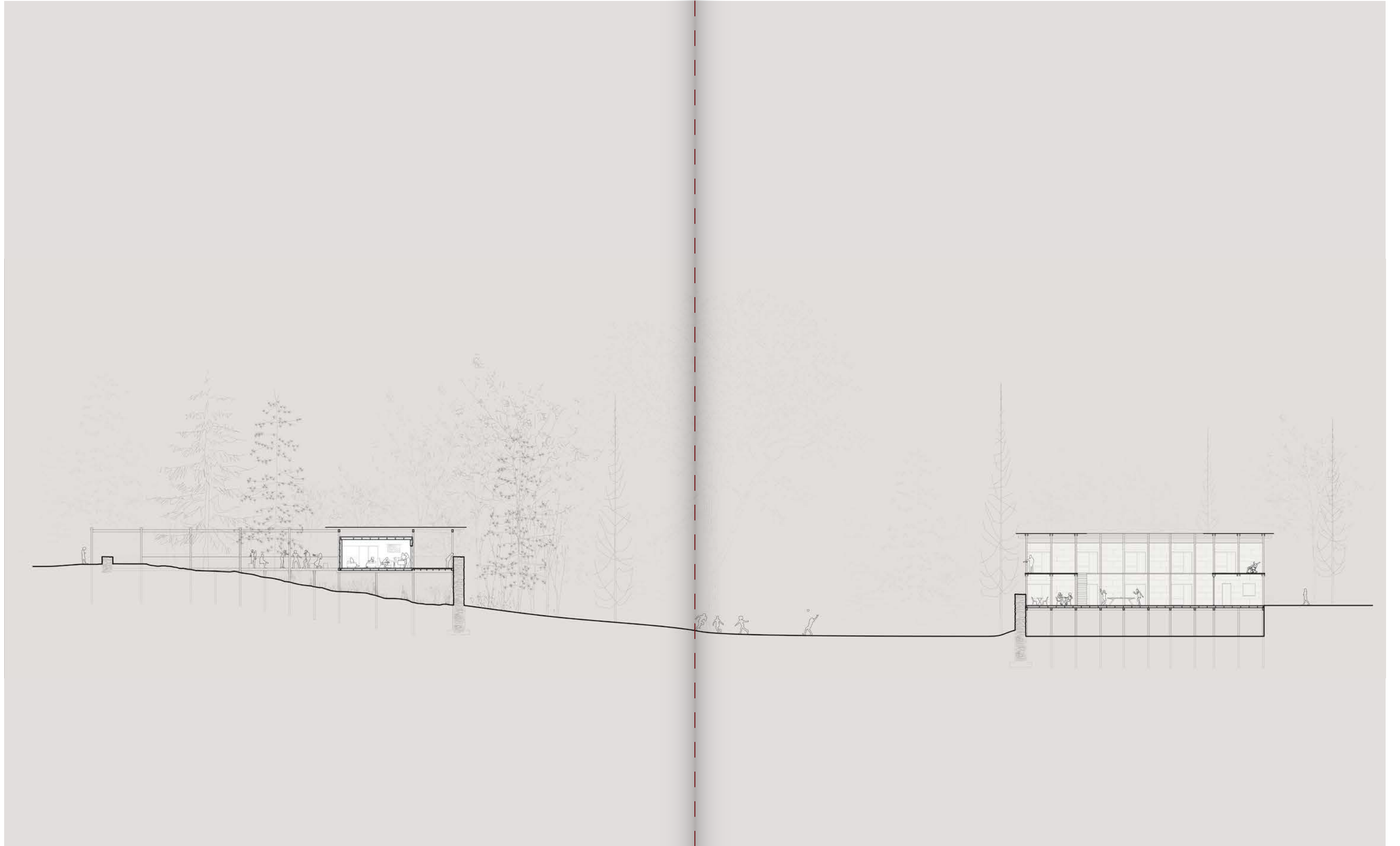

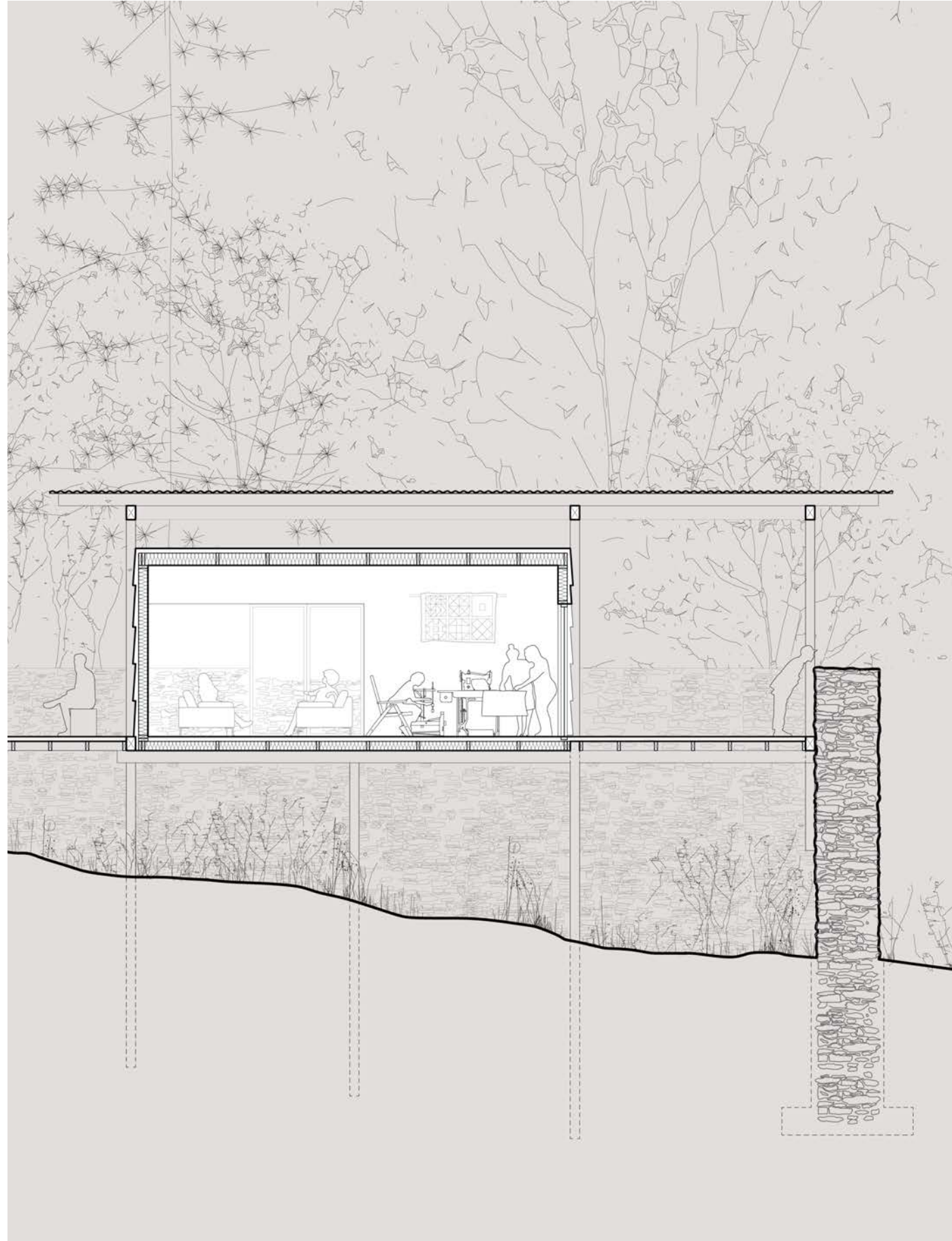

craft center section

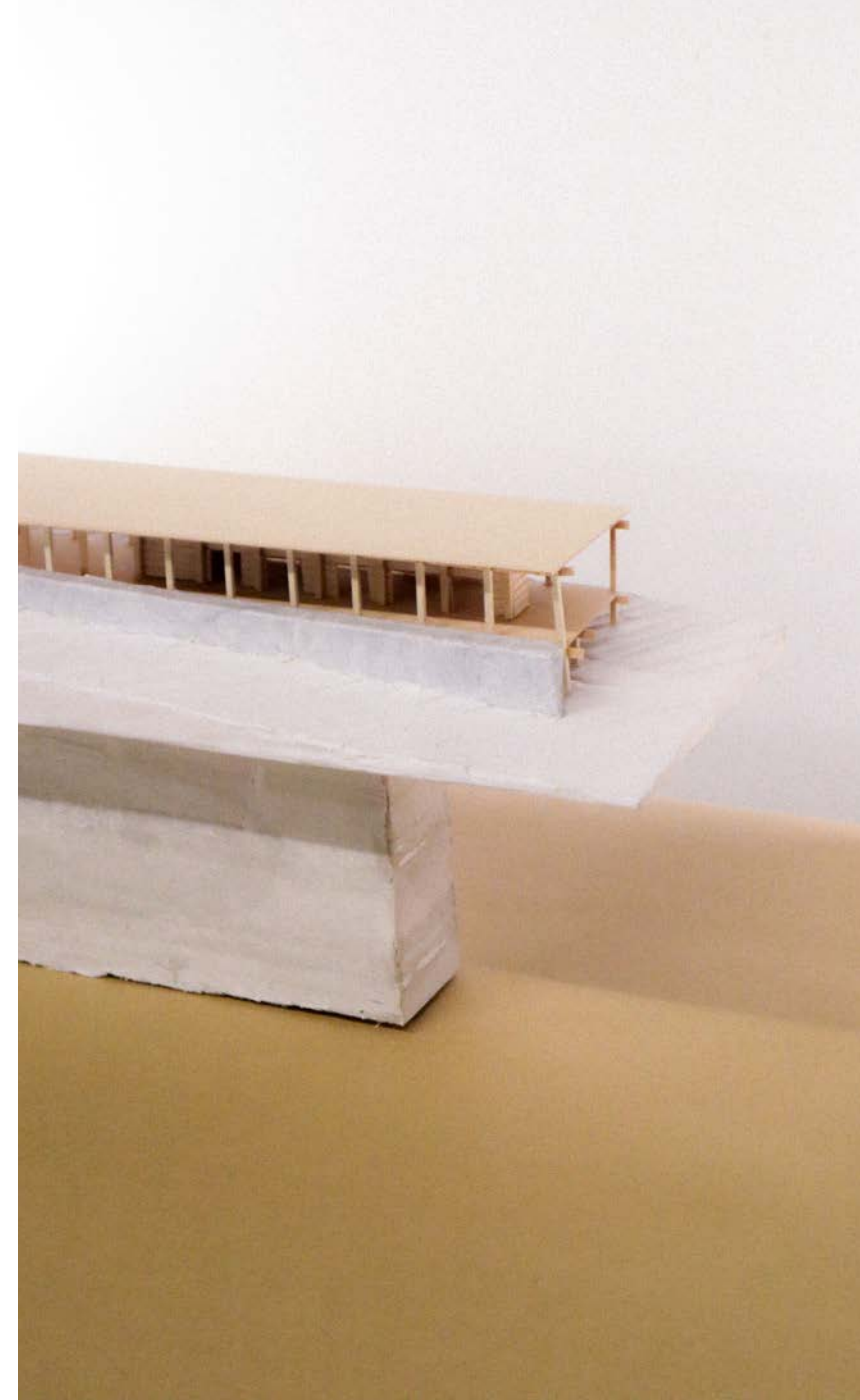



transitional housing courtyard view

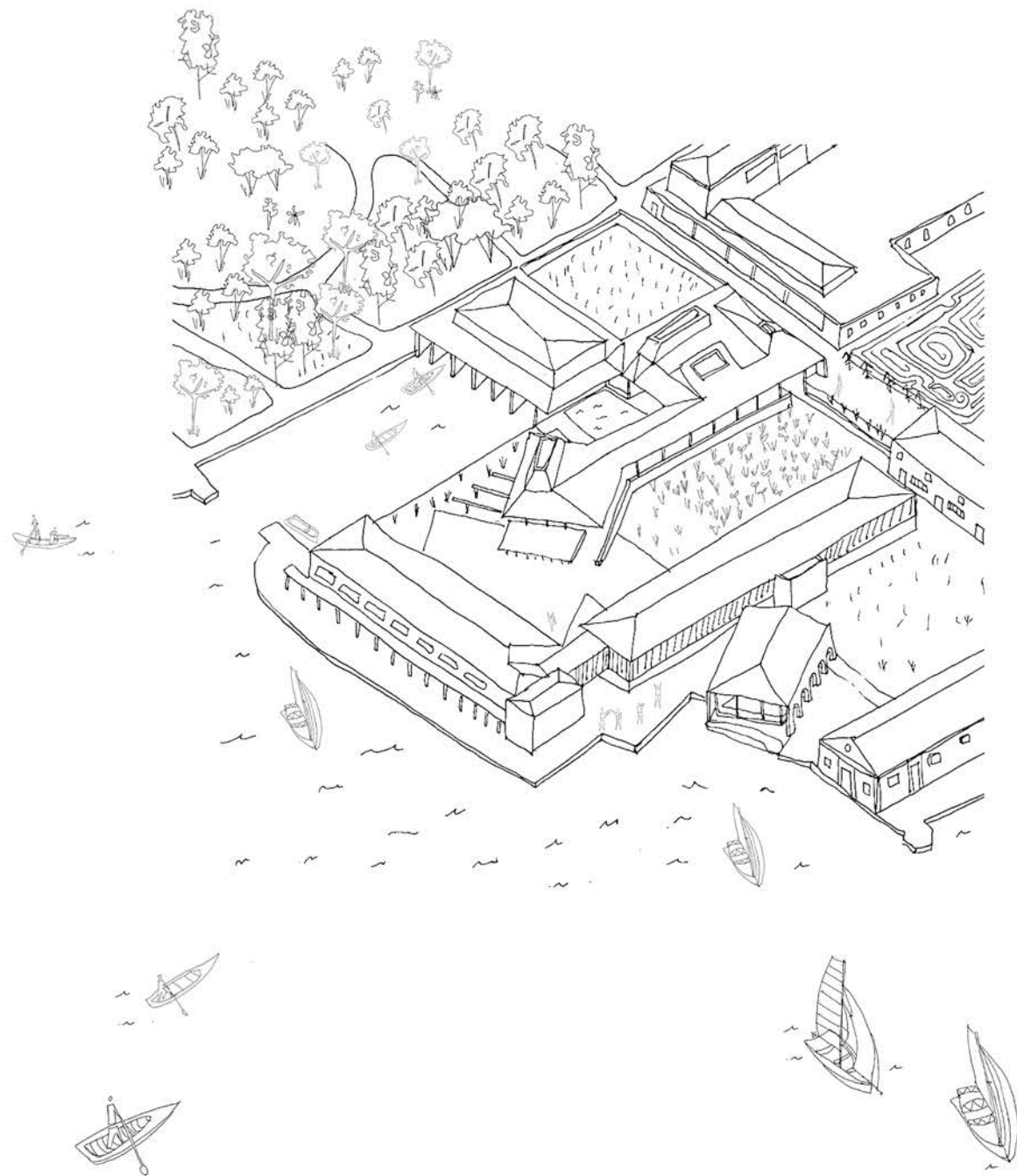

02

Leveraging Craft

Museum / Public Squero
Adaptive Reuse

Isola di San Giorgio Maggiore,
Venezia, VE, Italy

Professor
Jorge Otero-Pailos,
Mark Rakatansky

Advanced V, Historical Preservation
Fall 2023

Leveraging craft studies water through the Venetian cultural practice of rowing. Individual to Venice, *Voga Alla Veneta* is the style of rowing in which the rowers are standing up, facing forward, and utilizing an open oarlock known as a *forcola*. This practice in Venice has been decreasing over time due to the difficulty of owning a wooden boat in Venice today. However, those who still honor this tradition come together for multiple regattas a year and sport their craft in competition.

The design transforms an existing pool building, established for the Nautical school on the island of San Giorgio in the 50's, into a public squero, a Venetian term for a boat repair shop. The craft of woodworking is essential to the practice of rowing. Therefore, the project tells the story of wood in Venice from extraction to creation. Visitors can watch the practice of boat making while simultaneously view the historical tools and paintings describing the ancient practice that is used today.



The existing building showcases a reinforced concrete structure, separated from the exterior shell of the building. Tectonically, the project speaks to the existing building but establishes a new structural language of utilizing wood. It consists of a wood structure with a metal rod truss, each reacting to the different exhibit spaces while emulating the asymmetry and counterbalance of rowing the Voga Alla Veneta. Angling off of the existing building, joined by the central pond signifying a culminating moment for the project in which the exhibit speaks about the future state of the water due to climate change and how rowing today not only continues on tradition but is a tool to protest for climate awareness. It represents an ancient craft that has always demonstrated sustainable practices and was established by taking lessons from the water, not working against it.

existing pool building

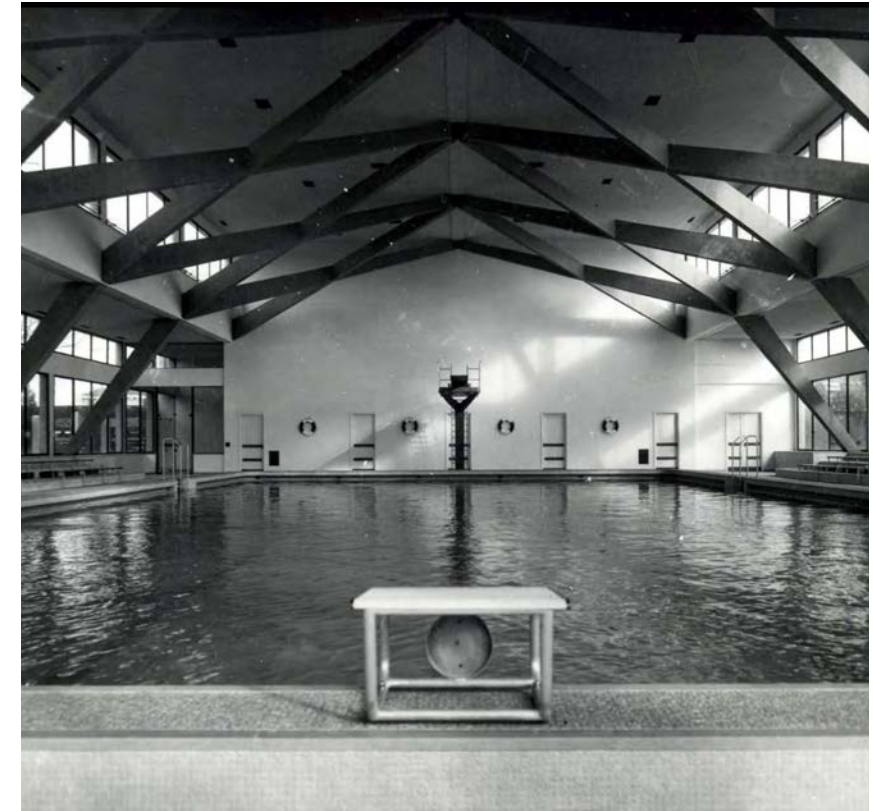
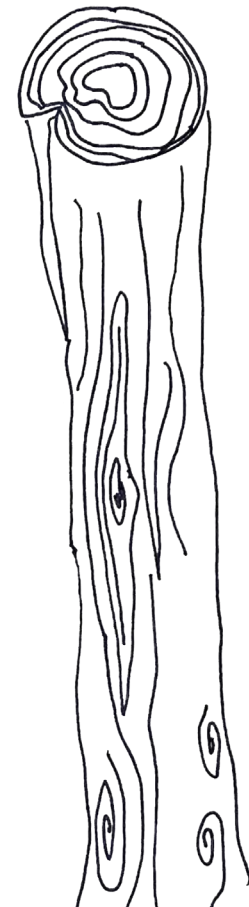
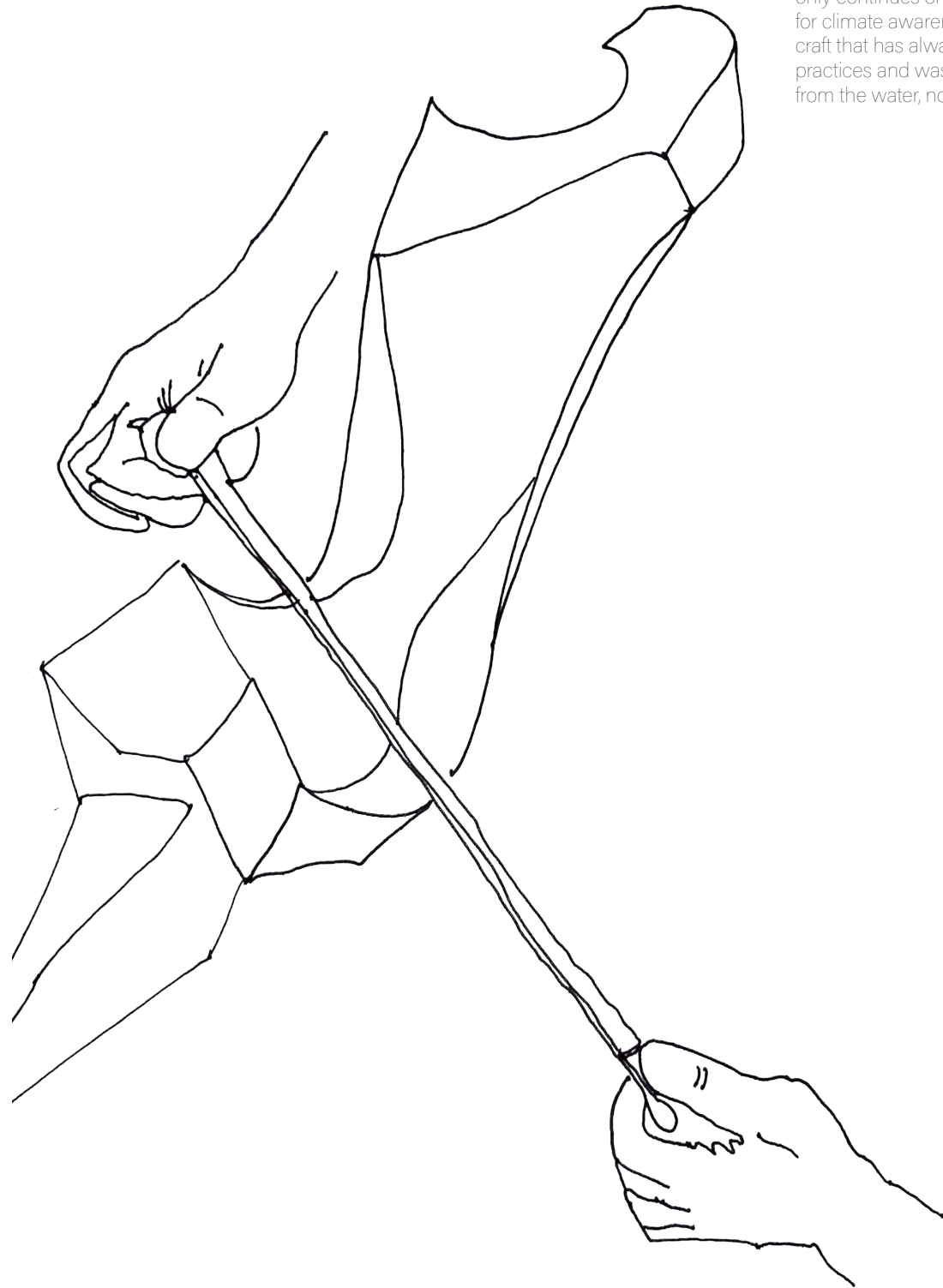

a





b

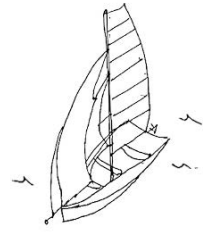

c

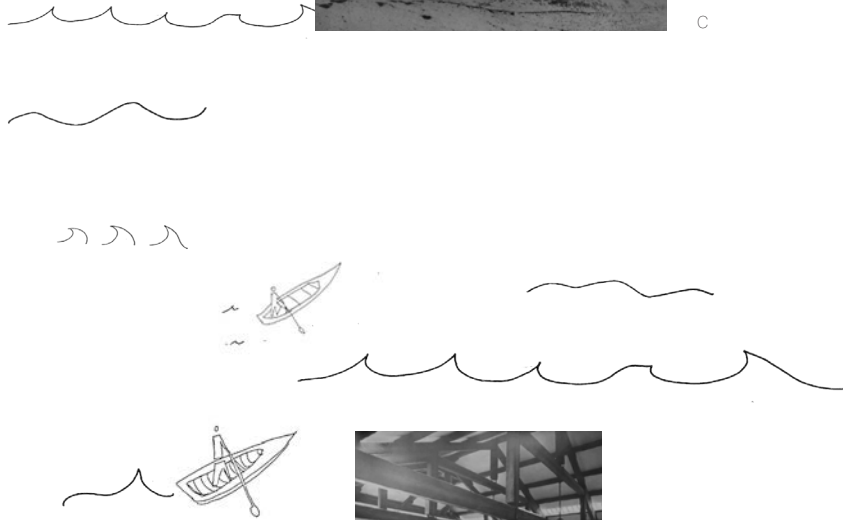

d

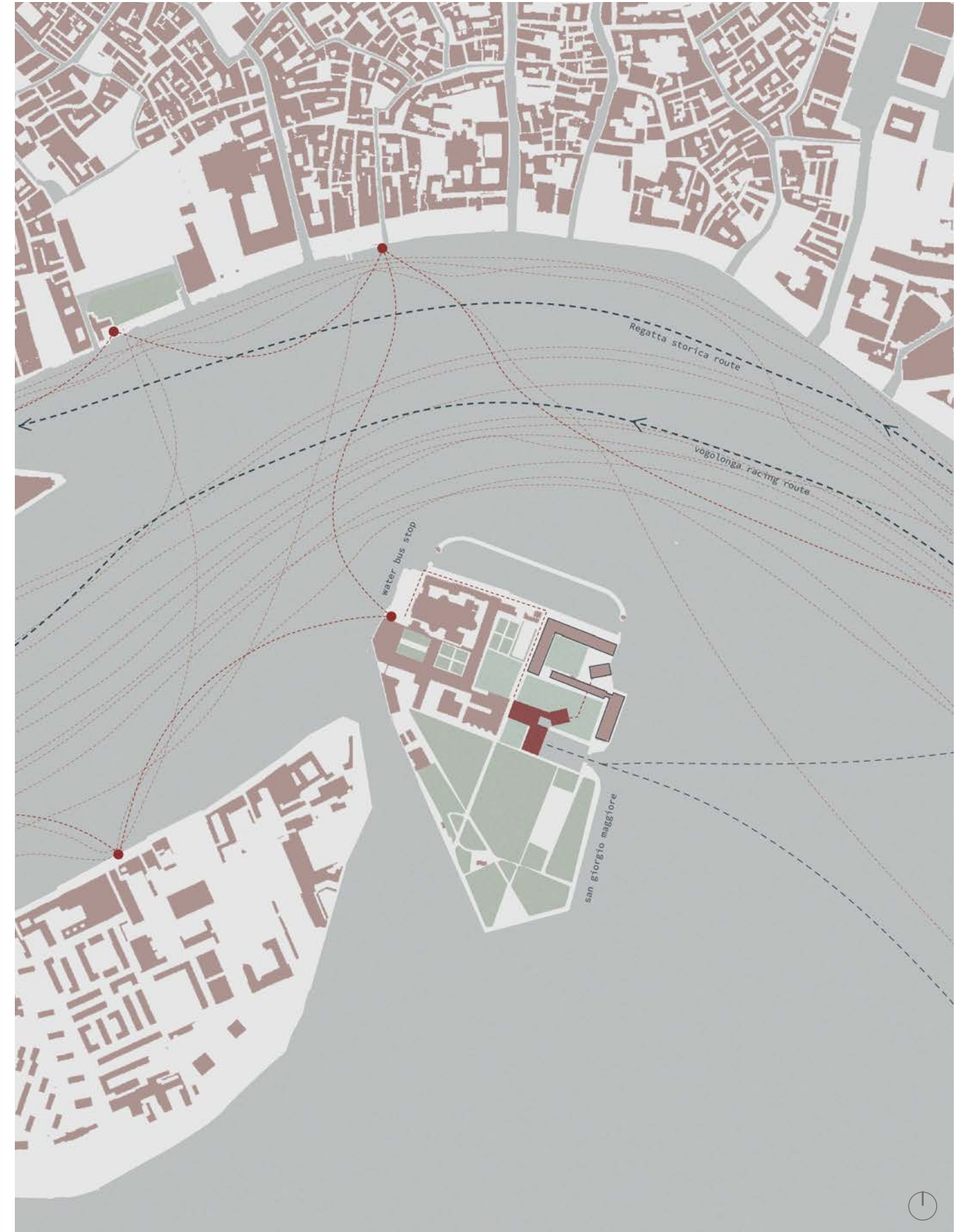

imparare a la voga alla veneta; learning to venetian row

background

organization; Row Venice
our Instructors; Luigina Davanso + Laura Petard

Luigina has participated in the exclusive Regatta Storica more than 20 times, and is currently national champion of the national club rowing circuit (CIR - Club Italiano Rematori) together with Jane, who is her rowing partner.

boat: batela, a larger row boat previously used for cargo. It is easier to balance on because it is heavier, therefore best for beginners.

I noticed that in the Regatta Races, woman ride their own specific boat

"Yes, they go on a boat known as the mascareta. There is evidence that woman were racing in the 1700's. Although it stopped for awhile they are back racing, which Row Venice has multiple woman who race in. Luigina is one of our veteran racers.

The Regattas utilize all different types of boats. The pupparin, gondolina, which is a faster thinner gondola and more. All of the boats have different color and on the day of the race, the clubs choose their colors for random selection of boats."

oh wow, so the racers dont use their own boats?

"no, to make the races fair, they have them randomized. We actually are able to stop by a remare storage if you would like to see where many of these boats are kept"



How many races are there a year?

"I think it is six official races - speaks to luigina in italian to confirm. There are other ones that are not as official. They are have now a more standardized national rowing circuit known as Vip short for voga in piede. Luigina also races in this as well. many venetians feel though it is not authentic because it is not on a wooden boat and rather a thin metal one."

Are there alot of old boats to repair?

"Oh yes, so many. The main issue is the responsibility of owning a wooden row boat. Rowers want their own boat so they can practice all year round, and they take much pride in their boat. However, its diffcult in venice to do so. The parking itself, where to keep the boat, is very hard to come by and expensive. The biggest problem though is that there is not a single open public space for rowers to work on their boat annually. Instead we have to take them to small cramped spaces in back alleys, which is very difficult to work on. The wood boat requires maintenance every year, but there are no public spaces to maintain."

now its my time to try to voga all veneta

put right foot forward, (here where the wood is worn down)

left foot back

extend your hands straight out pushing forward with your front foot. then pull your arms back by shifting weight back.

The oar should be flat out of the water

slightly twist wrist to turn oar as it goes into water.

The forcola acts as a lever and propels you forward

... wow this is hard, I cant seem to balance my feet and get into the rythm, but luigina is saving my bad rowing by being in the poppiere positon standing on the helm

pull the oar in as we approach a narrow waterway

... we exit the canals still water and enter the open water of the lagoon, everything gets drastically harder. the wake is stronger, and my shoulder gets tired.

Voga alla veneta : venetian rowing



me learning Venetian rowing in Venice!!

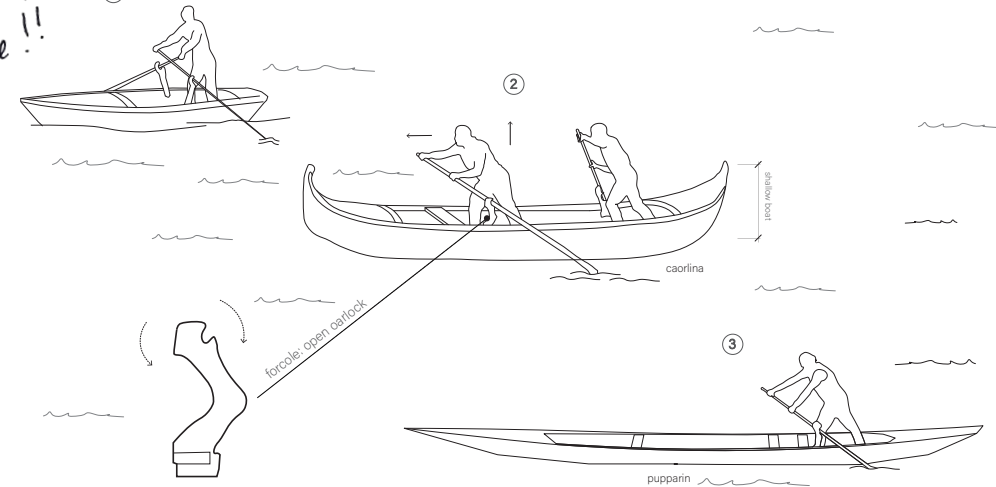

- stucco surface change
- stucco detachment
- stucco patching
- exposed structural rebar
- concrete disintegration
- additions
- broken architectural features



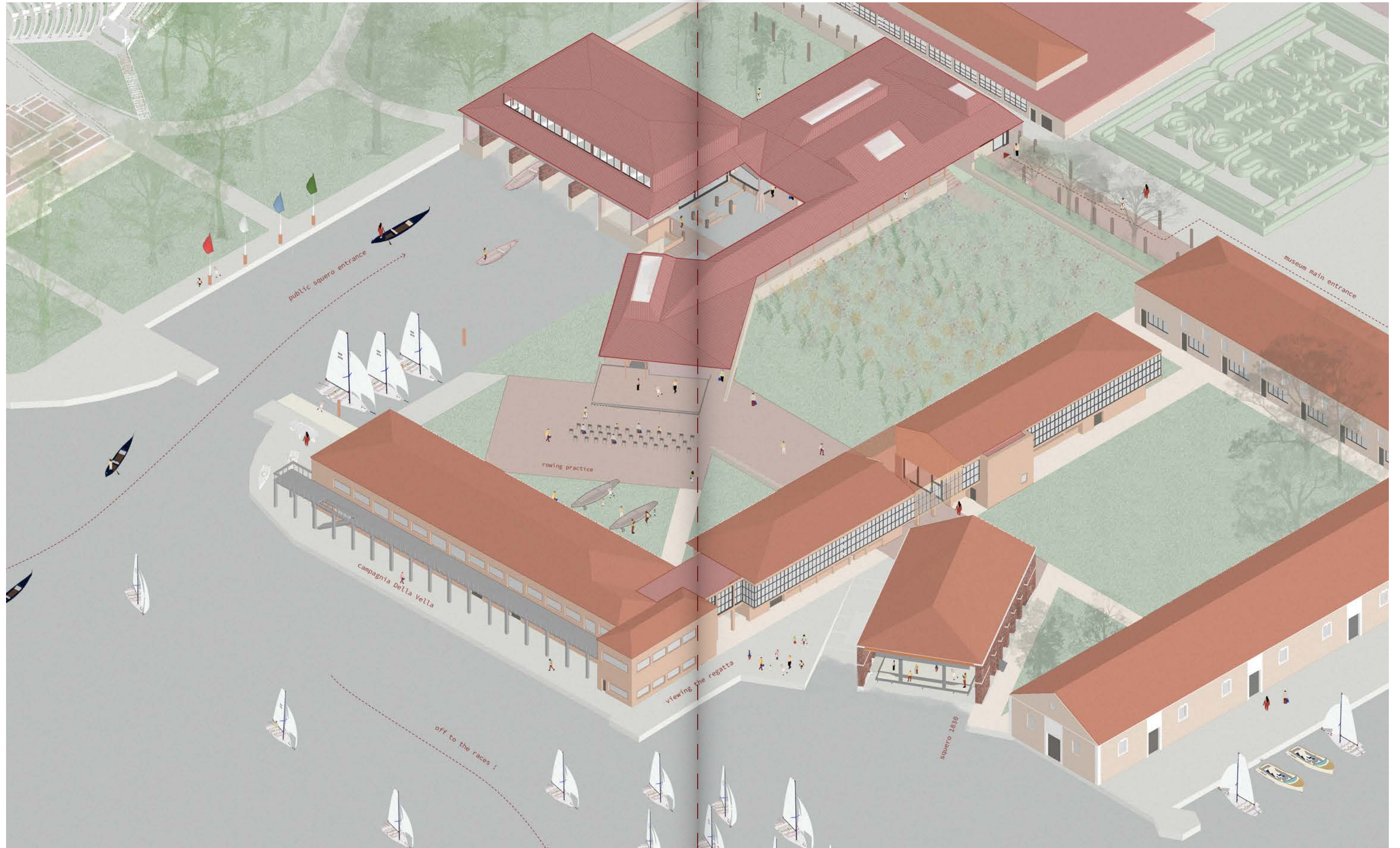

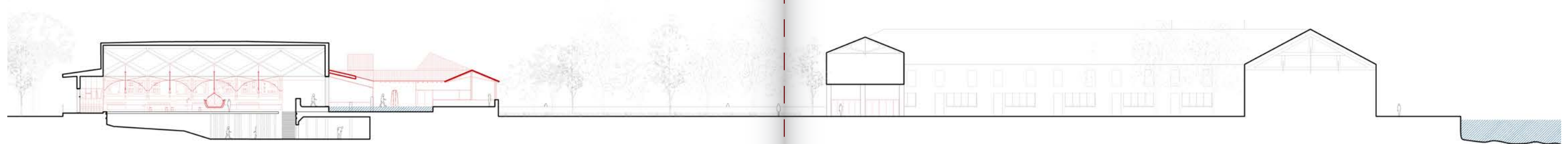
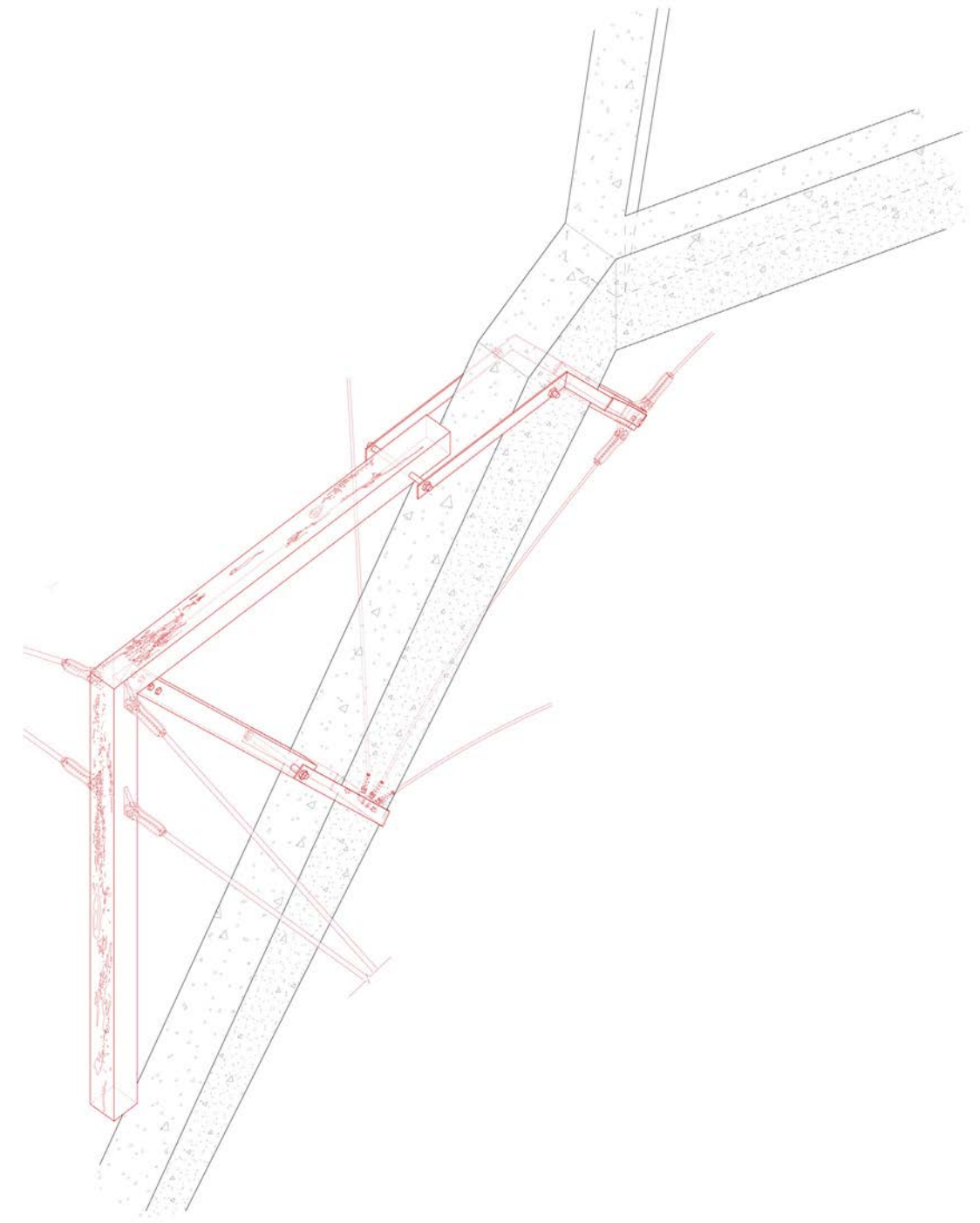
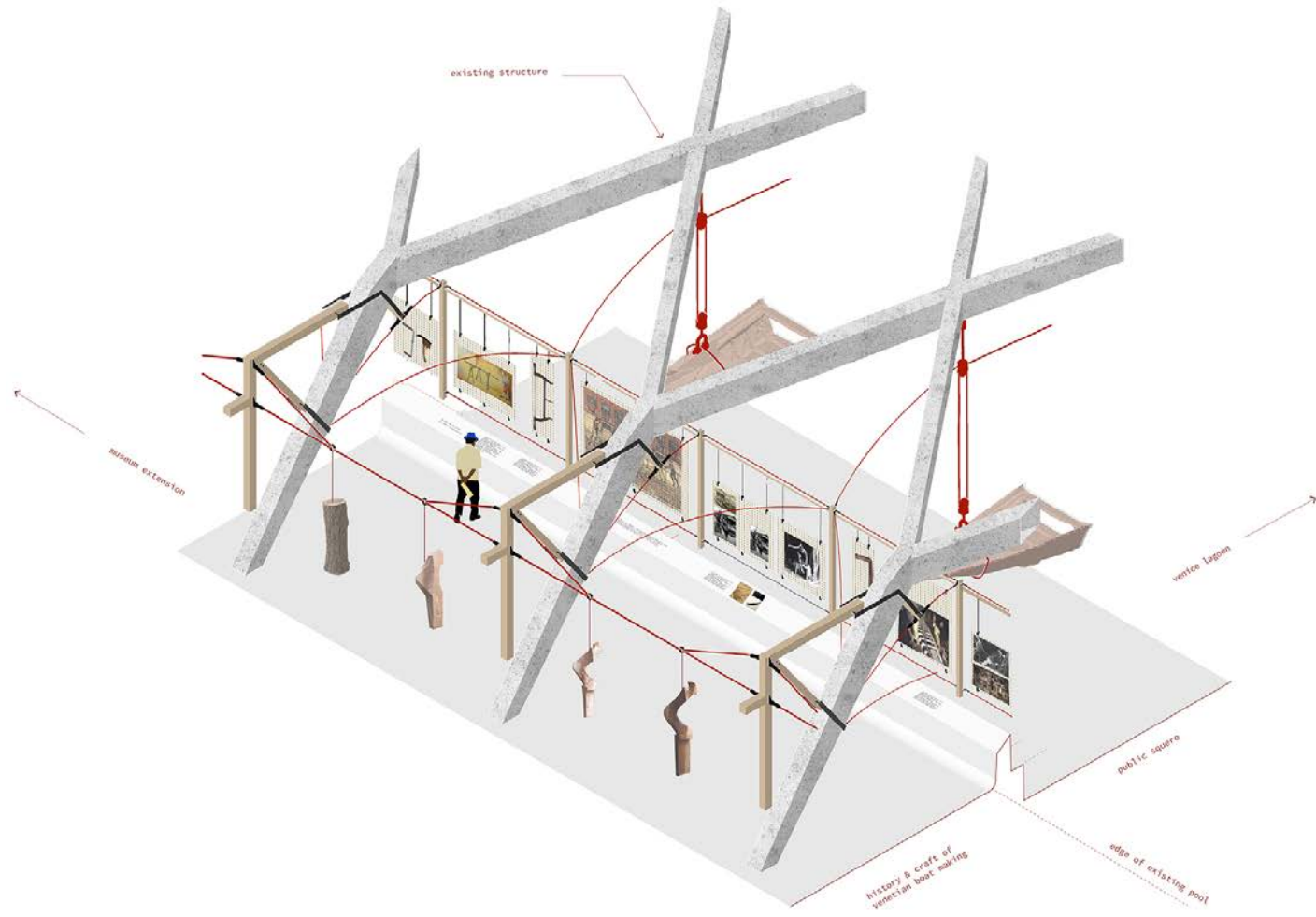

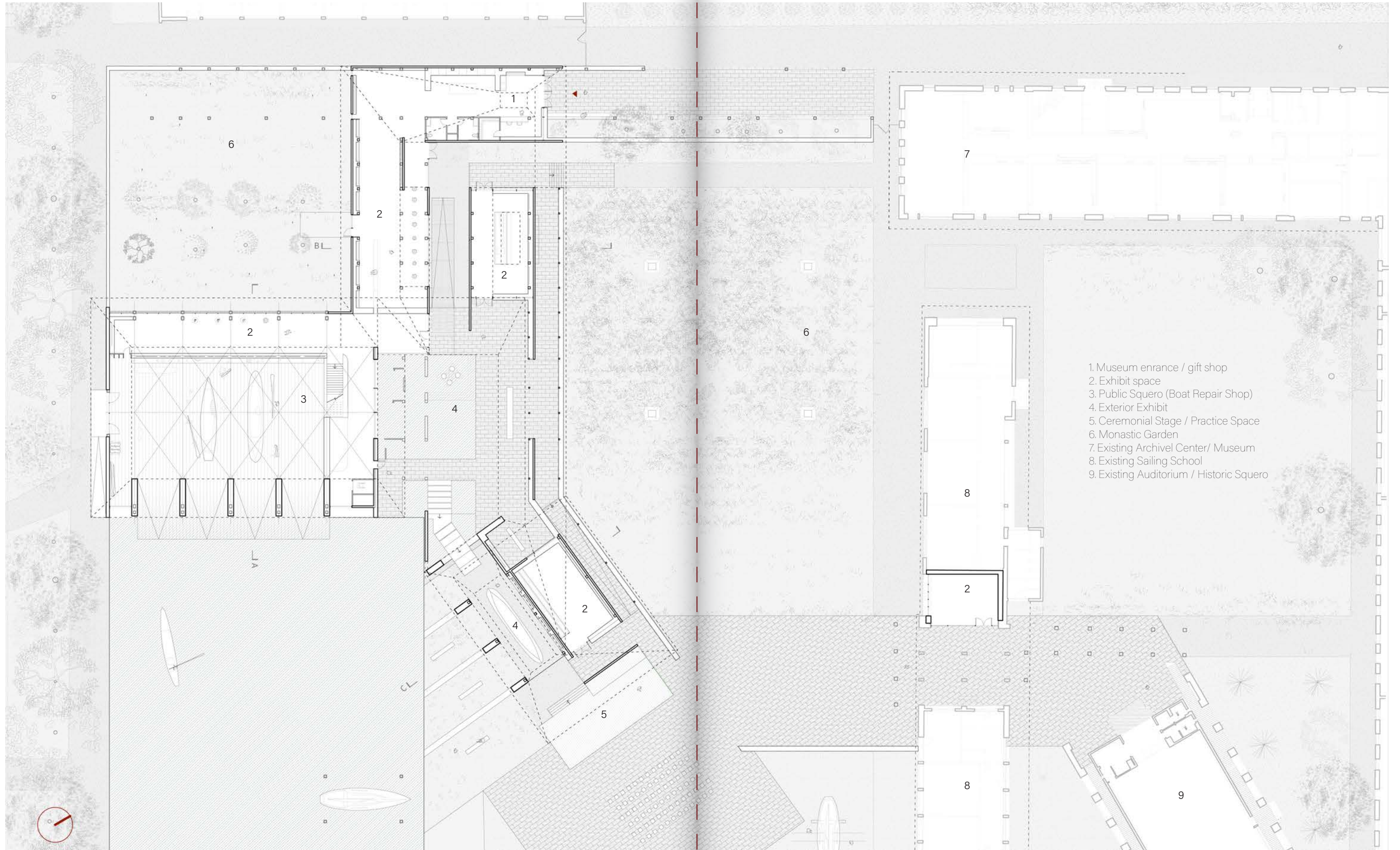

- 1. Museum entrance / gift shop
- 2. Exhibit space
- 3. Public Squero (Boat Repair Shop)
- 4. Exterior Exhibit
- 5. Ceremonial Stage / Practice Space
- 6. Monastic Garden
- 7. Existing Archivel Center/ Museum
- 8. Existing Sailing School
- 9. Existing Auditorium / Historic Squero

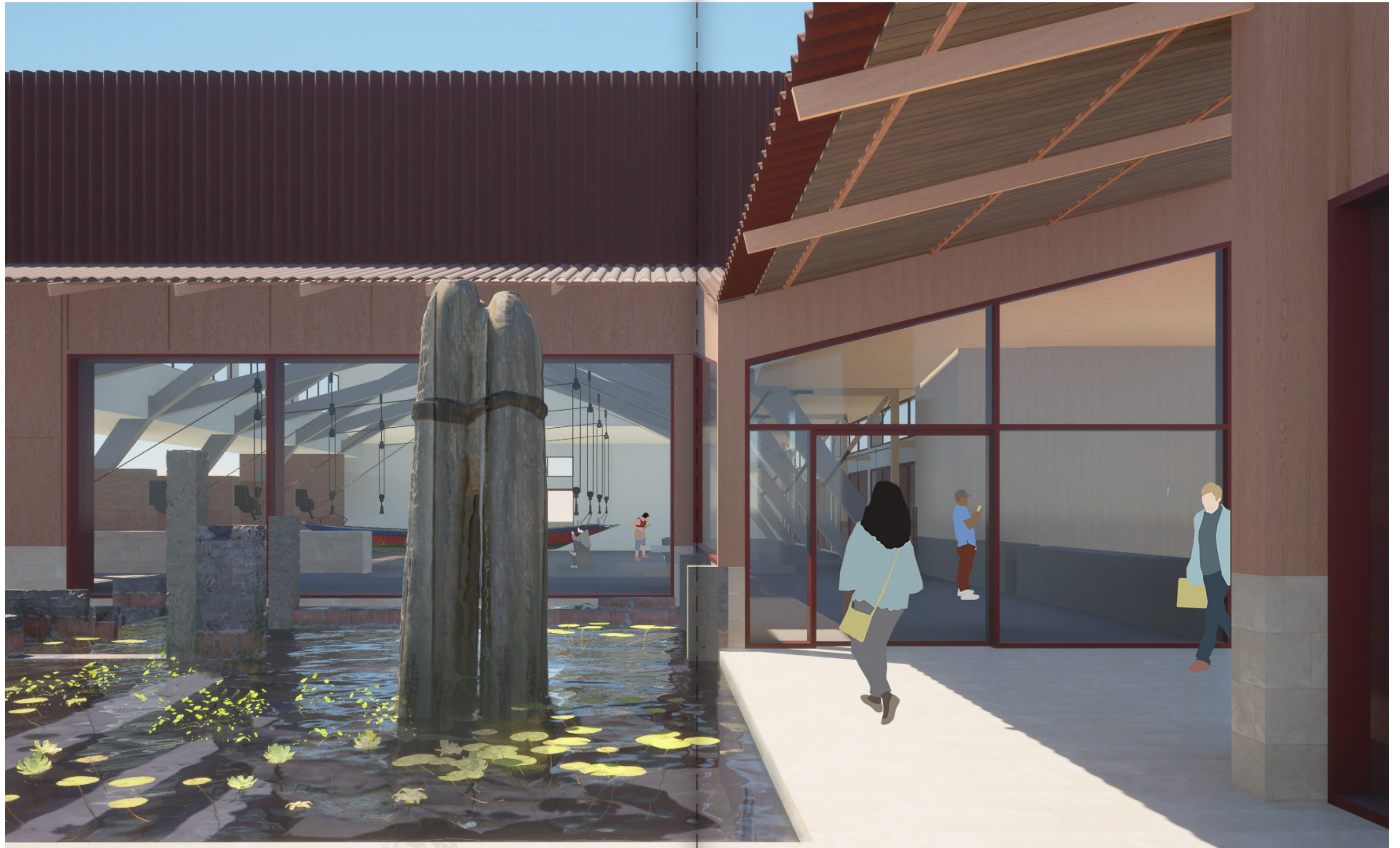

courtyard view

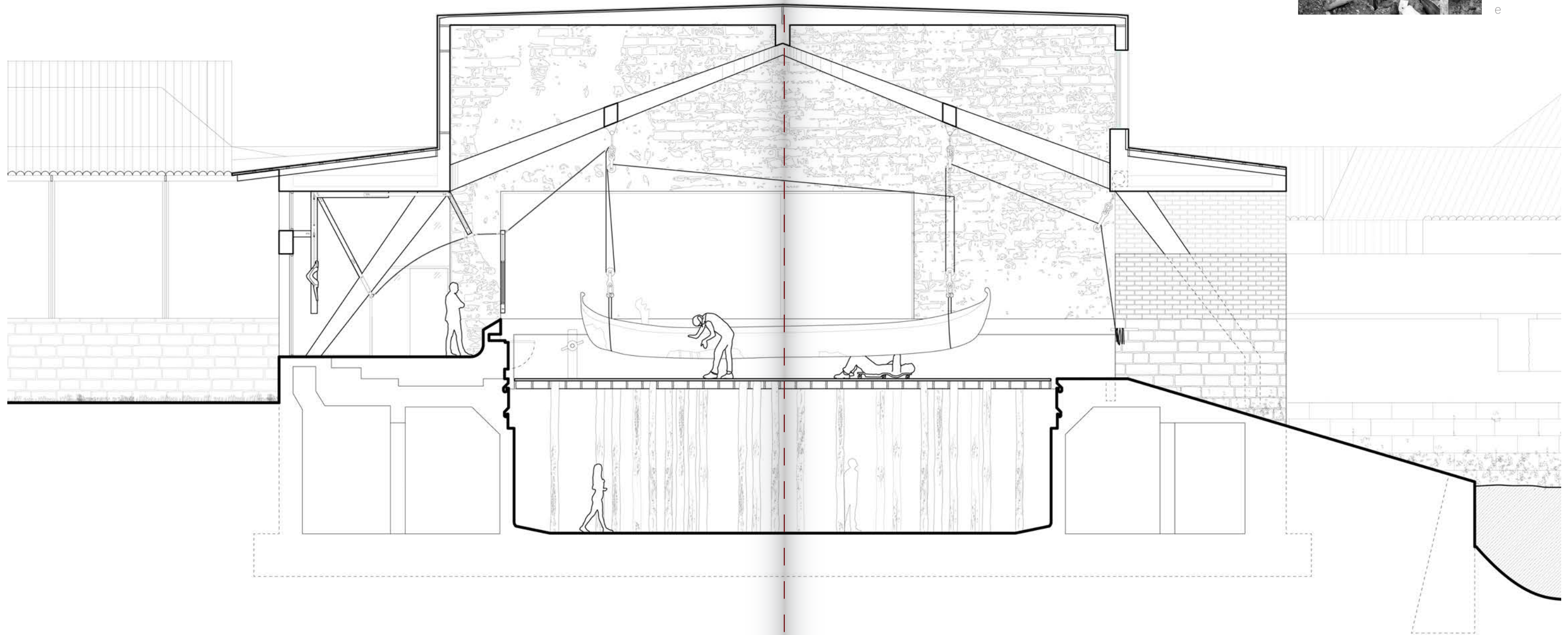
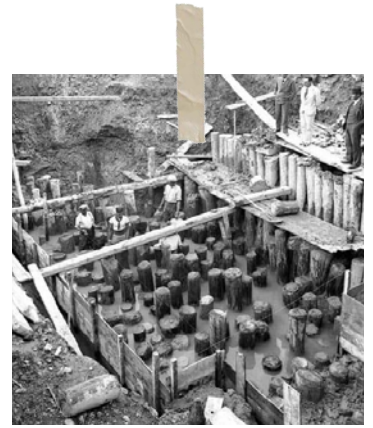



existing building workshop view

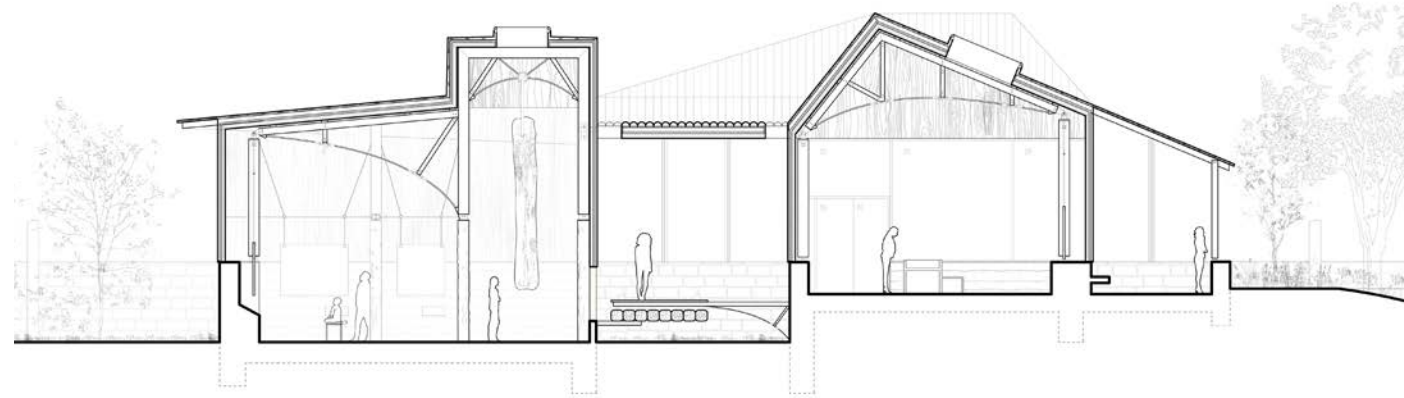
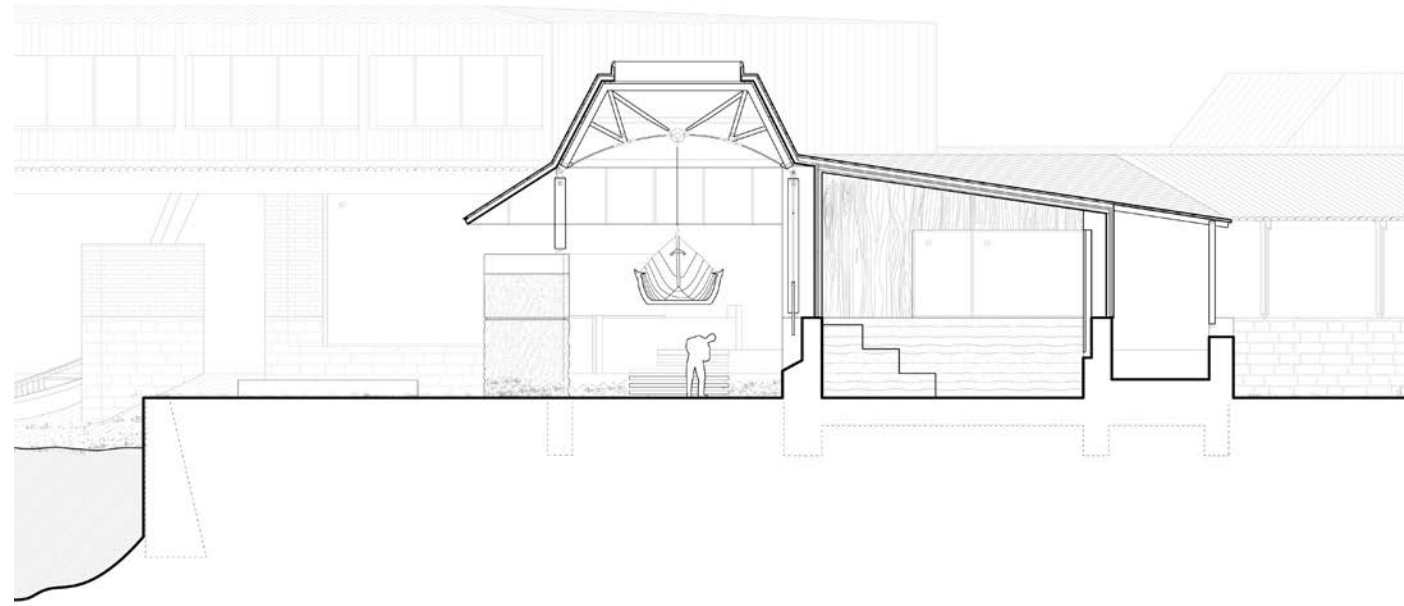

new addition section / view

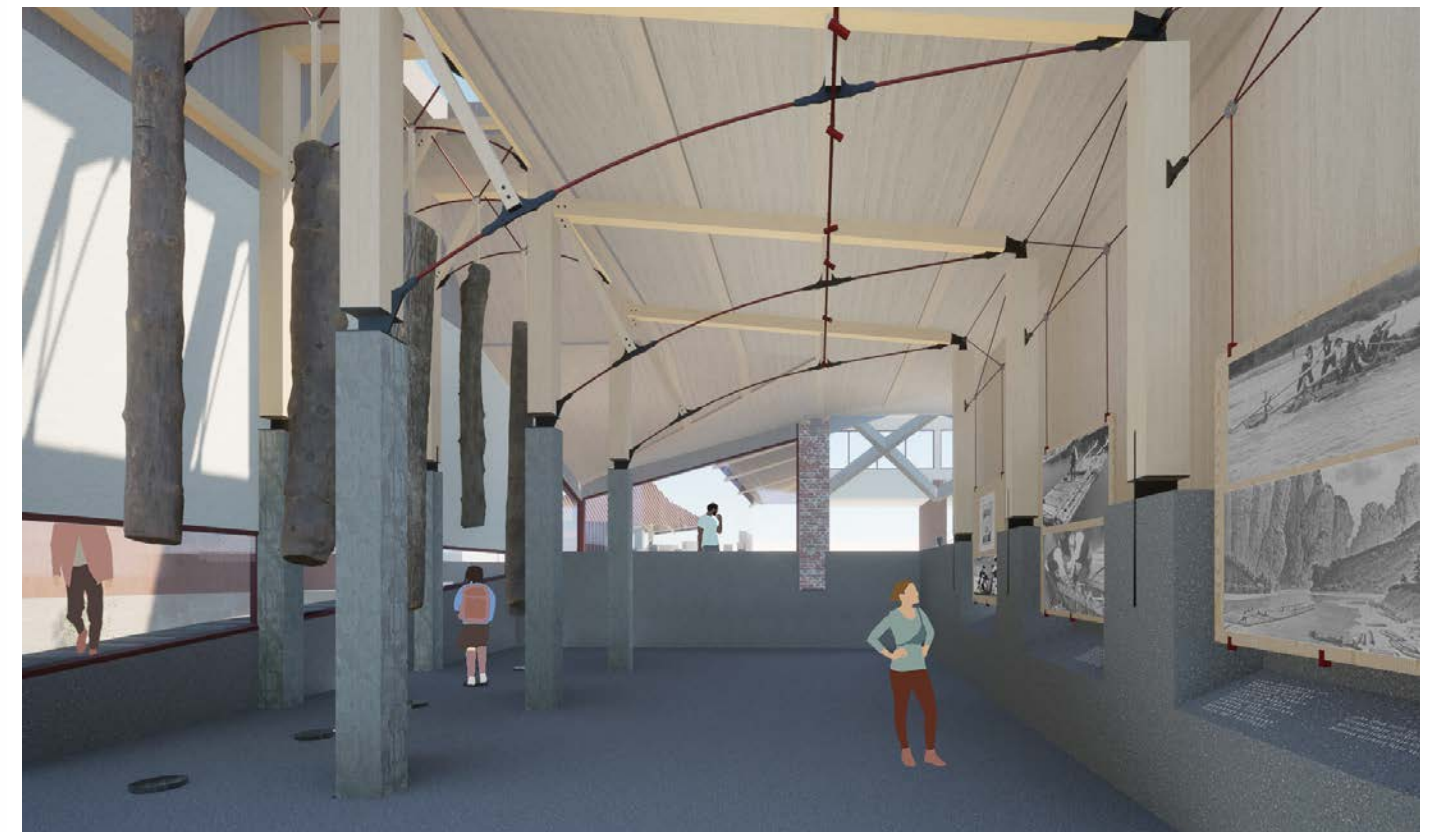

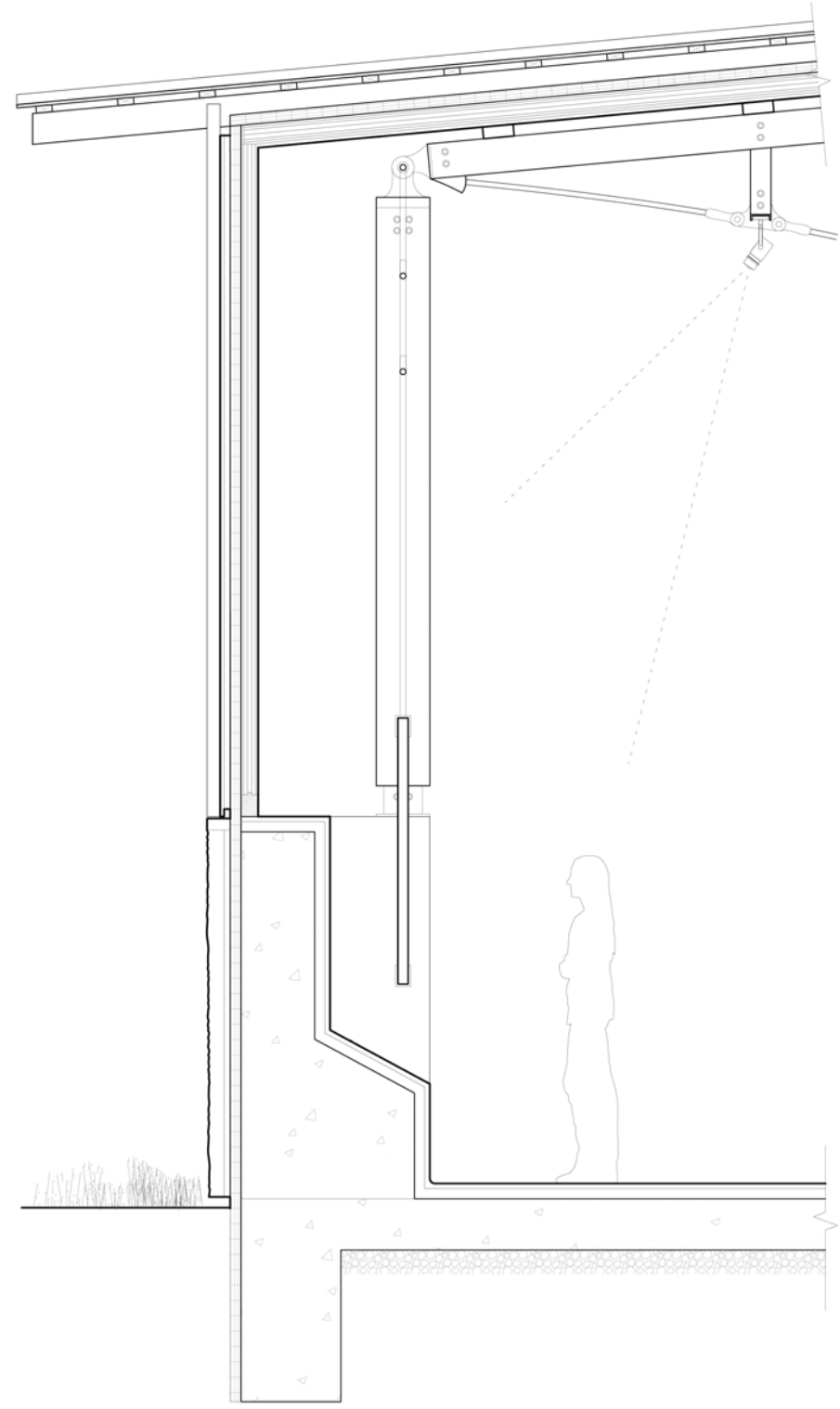

new addition wall section



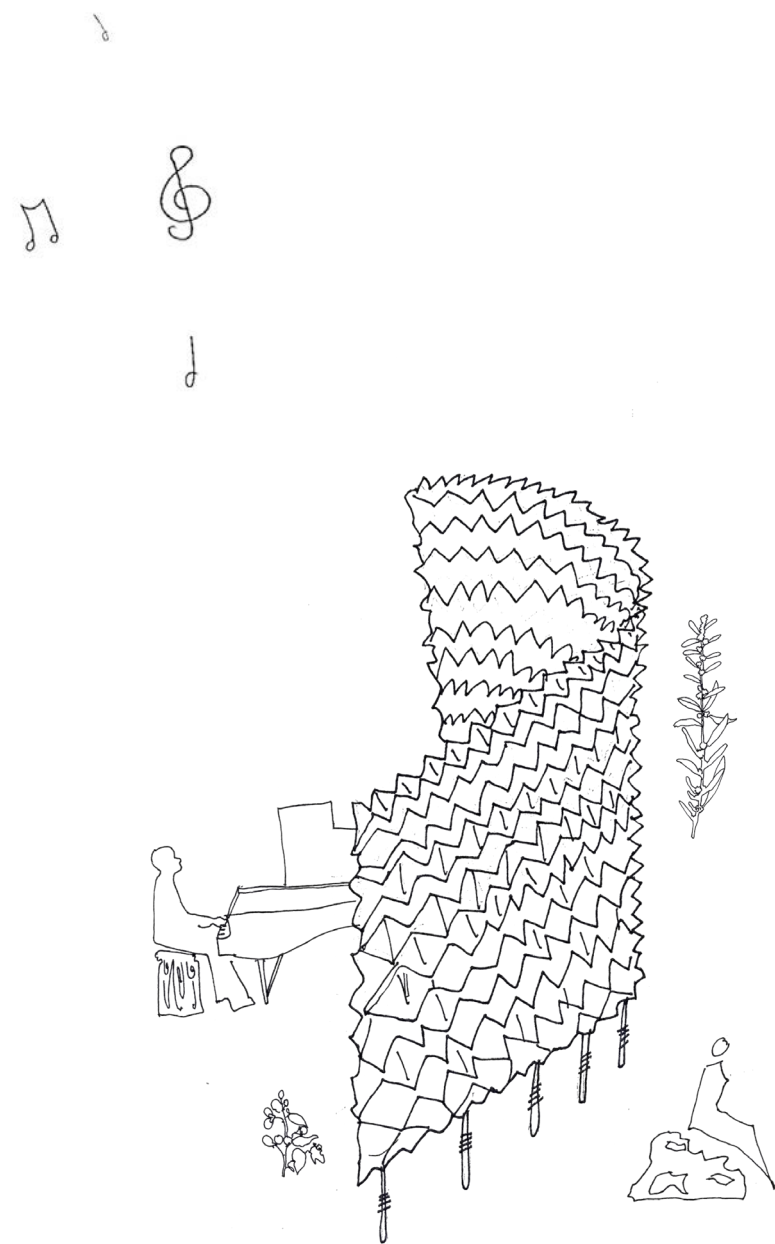

03

Breathing
Liberation

A Place to Breathe /
Recording booth
Seneca Village, Central Park, NY

Professor
Ilze Wolff
Lafina Eptaminitaki

Advanced VI
Spring 2024

Breathing is the basis of human life, a practice our bodies do without asking it to. Yet, it can also be consciously practiced for healing, celebration, and sound, a practice long held by South Africa's indigenous communities. Within the film, a Brother With Perfect Timing, Abdullah Ibrahim demonstrates the method of Circular Breathing, a rhythmic dance of air and soul that echoes the cadence of South Africa's journey to liberation. Breathing through jazz becomes a spiritual practice for Ibrahim during apartheid, connecting him back to the land his ancestors once freely breathed.

The qualities that define a space to breathe are not necessarily physical but instead conjure a feeling of freedom, calmness, and liberation. As Ibrahim breathes songs of liberation in the recording studio he is transported to a place of memory. How could a place to breathe like a recording booth capture sound and amplify it, reverberating the histories of places hidden?

Through the technique of pleating, iterating from the qualities of acoustic sound booths, and dying from the herbs that once grew among those of Seneca Village, this tectonic becomes a vessel to breathe life back into a site of erasure and hold knowledge of ancestral history.

It seems impossible in the beat of New York City to find a place to breathe, but today many walk through Central Park for that very reason. Built in 1858, the park was described as the "Lungs of the City" by its designer Frederick Law Olmsted. The land that is now claimed for the public purpose of breathing, was home to the first and largest free black community in New York, Seneca Village. This autonomous black community thrived on the land establishing a home and a place to breathe safely. Exiled from their homes for the master plan of the park, their memory has practically been erased. The project studies the complex history public parks have established themselves on and therefore the deceptive claim that these spaces are for "all".

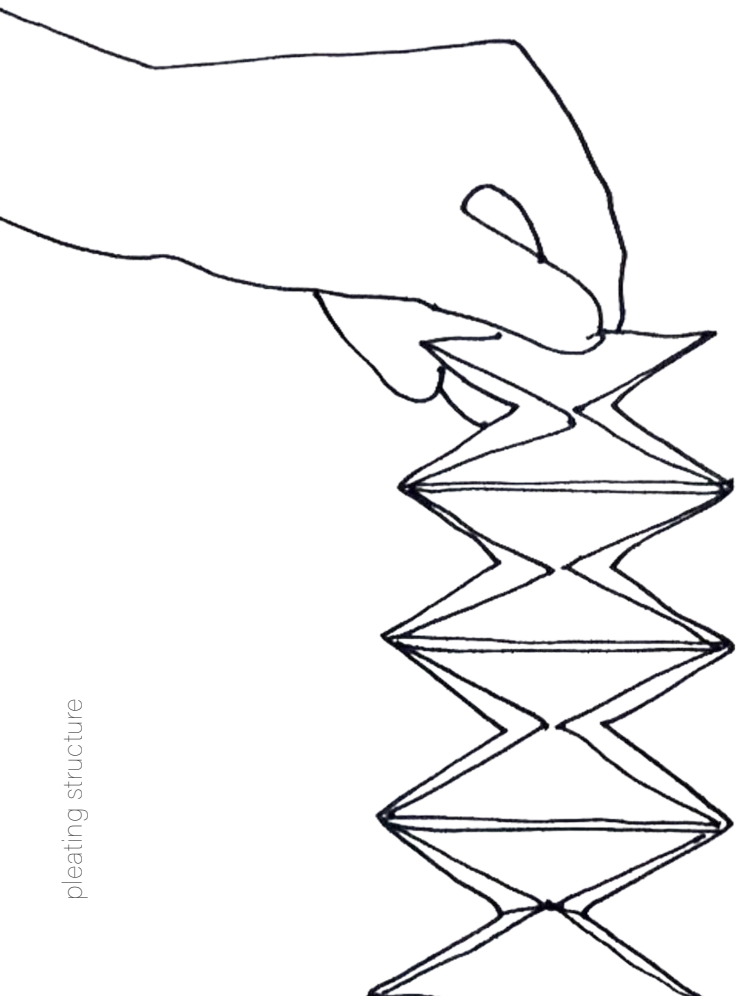

pleating structure





a



b



c



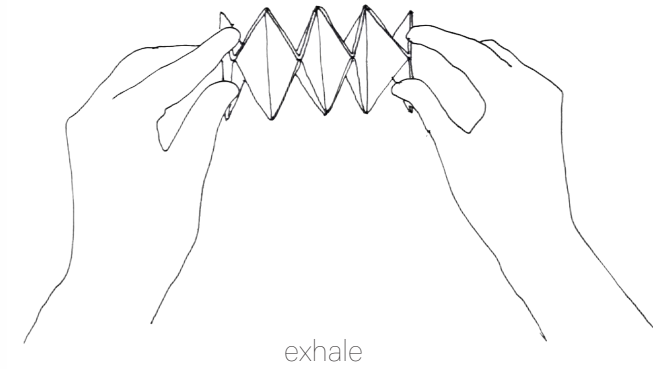
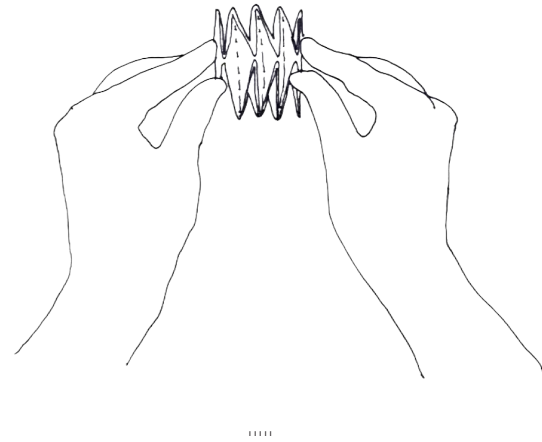
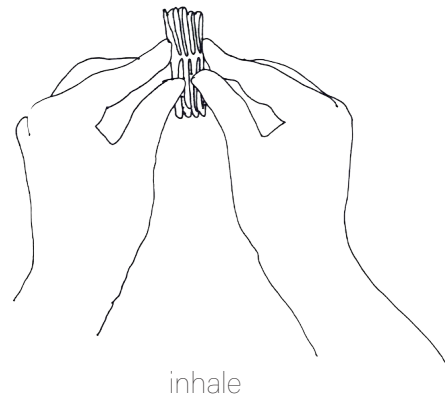

Re imagining Seneca Village

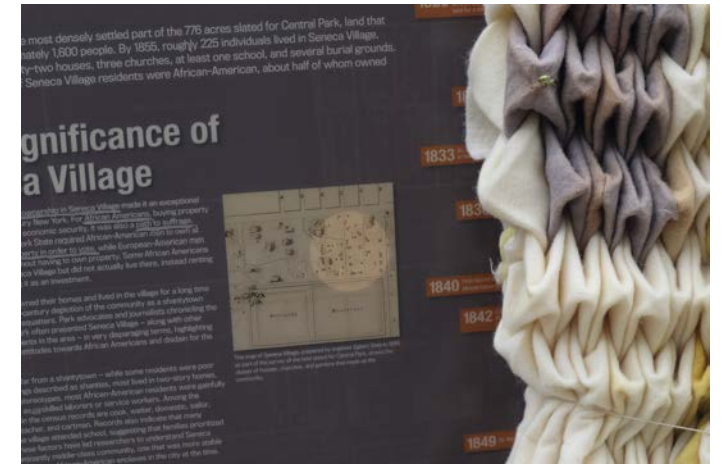





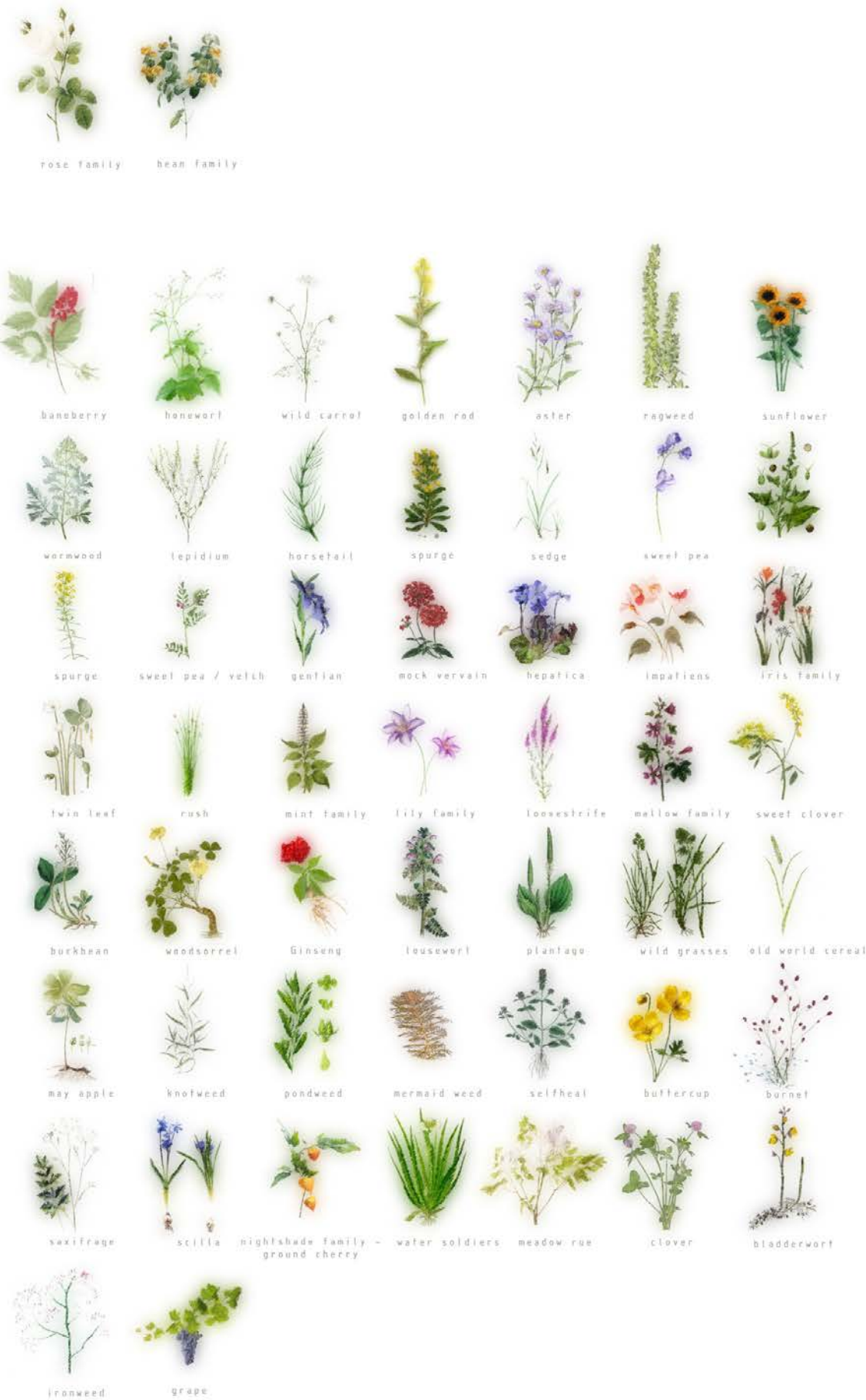
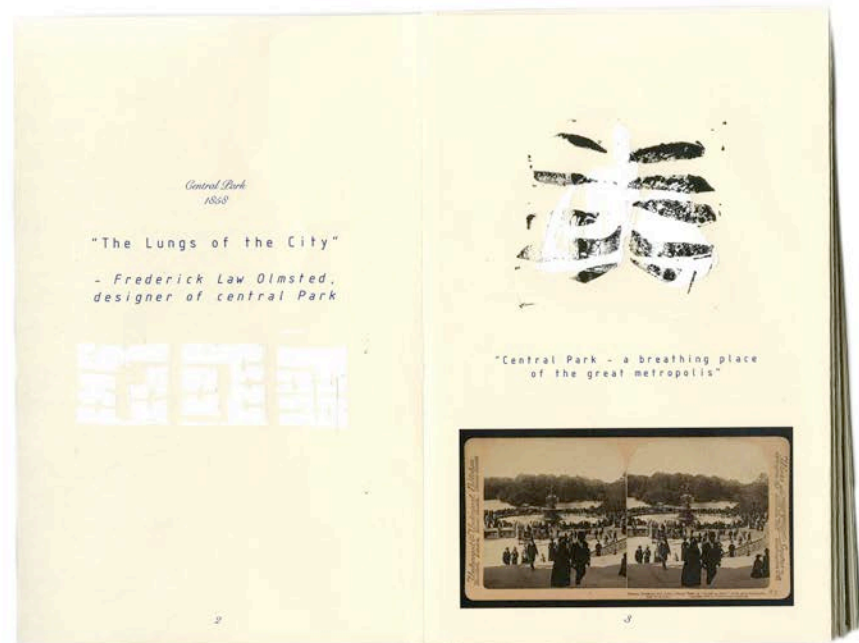

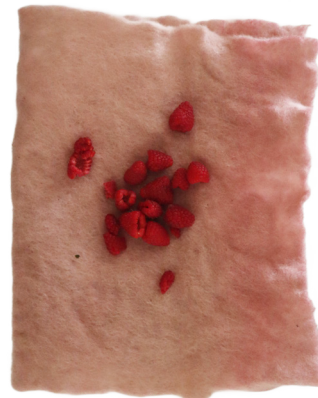

hand dyed wool









pleats at Seneca village



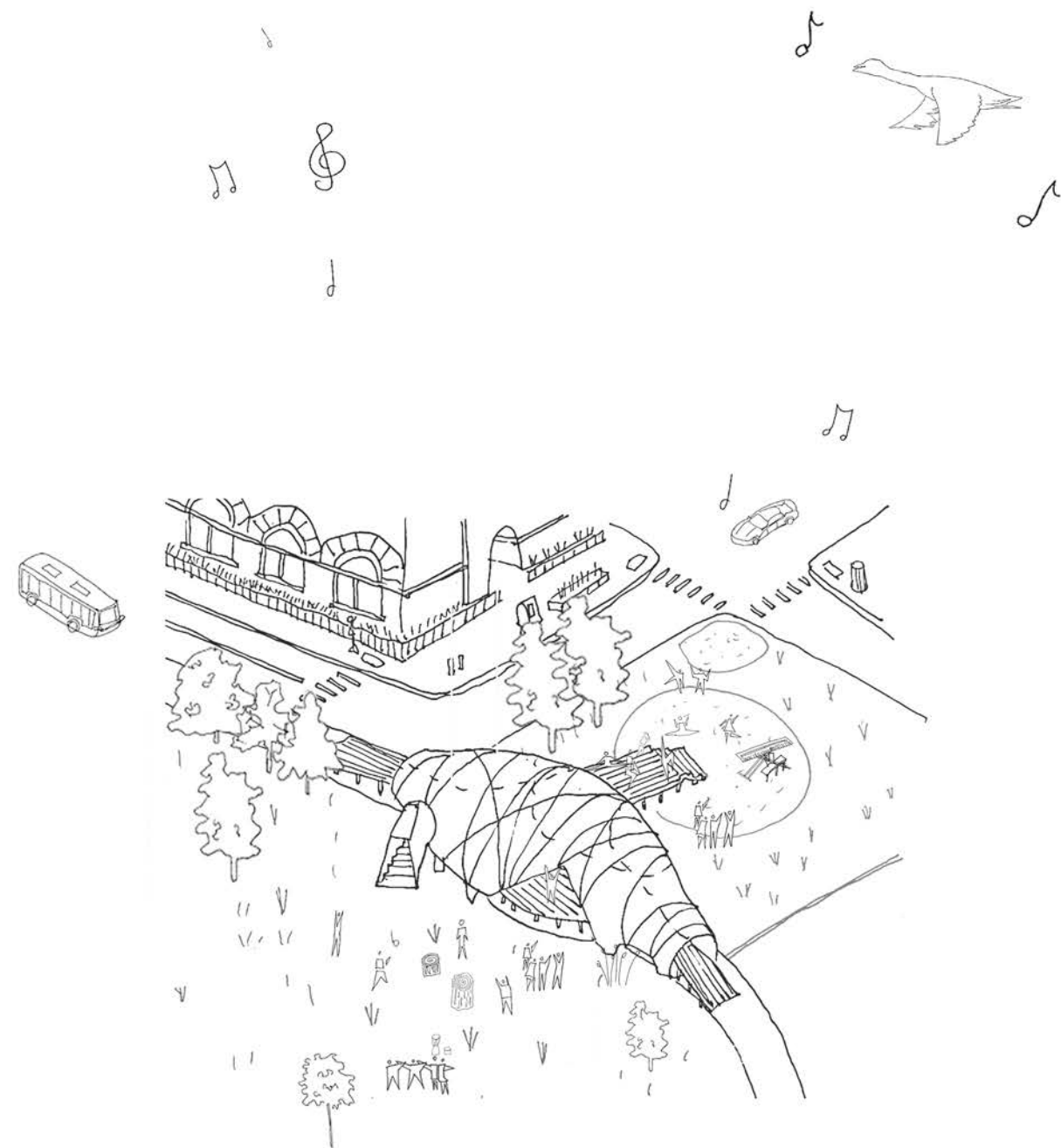

04

Harlem
Pulse

Performance Pavilion
Morningside Park, New York, NY

Professor
Lindy Roy

Core I
Fall 2021

St.
Lindy Hop
Now!

Professor
Jelisa Blumberg

Visual Studies Elective - Power Tools
Spring 2023

In Collaboration with Key Aiken

Harlem Pulse is a design that is brought to life by the community and exchange of people. Its located on the boundary of Harlem and Morningside heights. This boundary has a long rooted history of divide. This space becomes a gathering space for performance events. Locating the project on the sidewalk between the neighborhoods the concave structure can go beyond just a space for performance. The sidewalk along the park is absorbed into the form extending itself onto the street and connecting the median to the park, extending the park into Harlem.

As the scale changes in the form, the single structure can be occupied differently. The structure is altered by how its used, by its electrically charged surface. Embedded within the floor are piezoelectric sensors to light up the chamber. The space becomes performative and acts as an instrument for the community.

The Savoy theatre was a venue flourishing during the Harlem Renaissance. It established itself as a safe space to be free and wild. Although it no longer exists today, its legacy vibrates through the streets of Harlem. This project aims to capture and embody this spirit, merging the public park and theatre to re imagine an interior space for wildness.



a

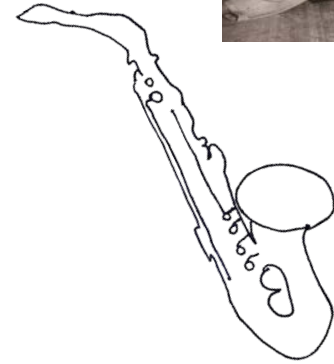

b



c

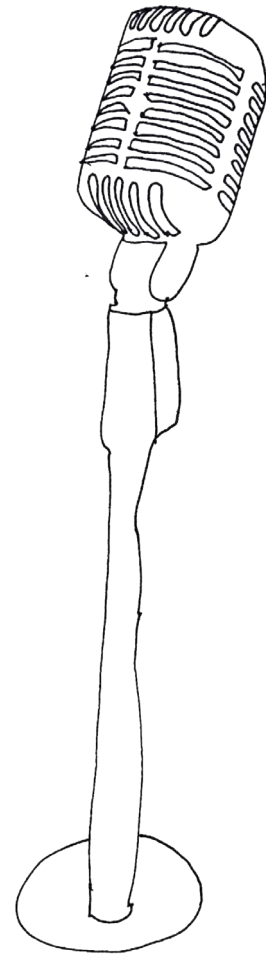

Harlem has a vibrant history characterized by spatial practices of the body. The Lindy Hop was a dance that was birthed in Harlem. Today, dance movements still come out of Harlem like the Harlem shake, and Chicken Noodle Soup. The spaces in which these practices are improvised have shifted throughout history. From a performance hall like the Savoy Theatre, to basketball courts. This project collapses history into an imagined performance space where the body can move freely.



Savoy theatre model

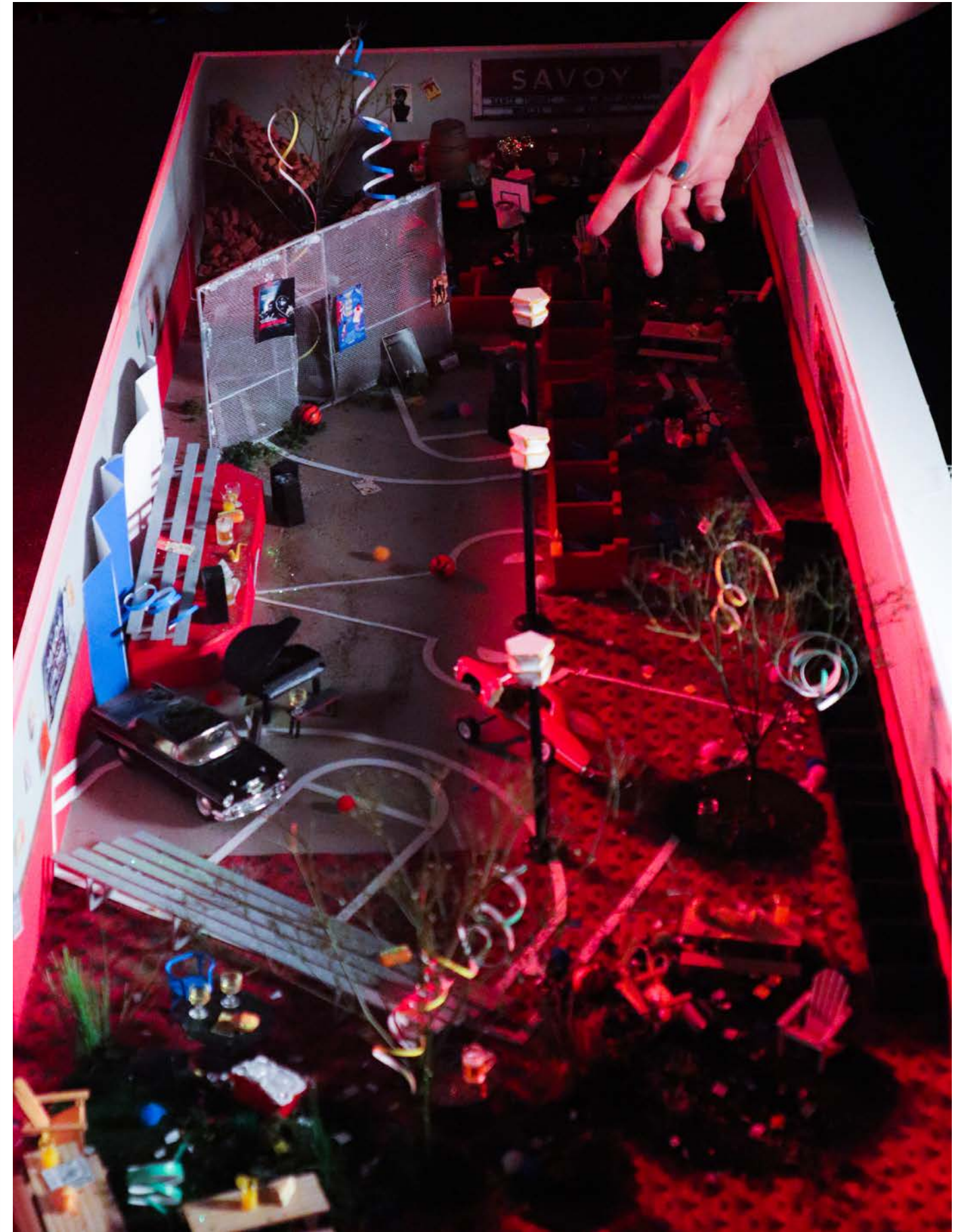

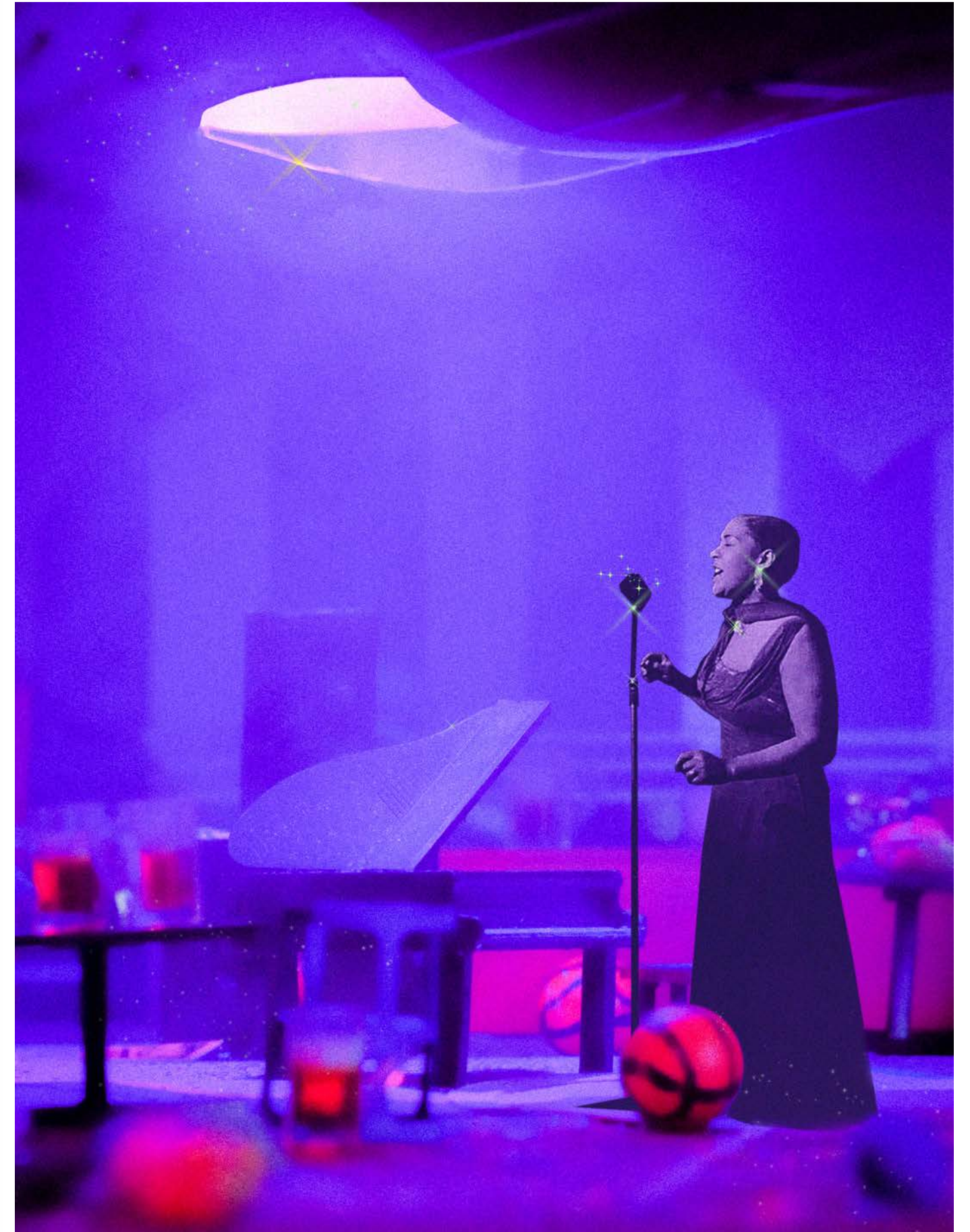
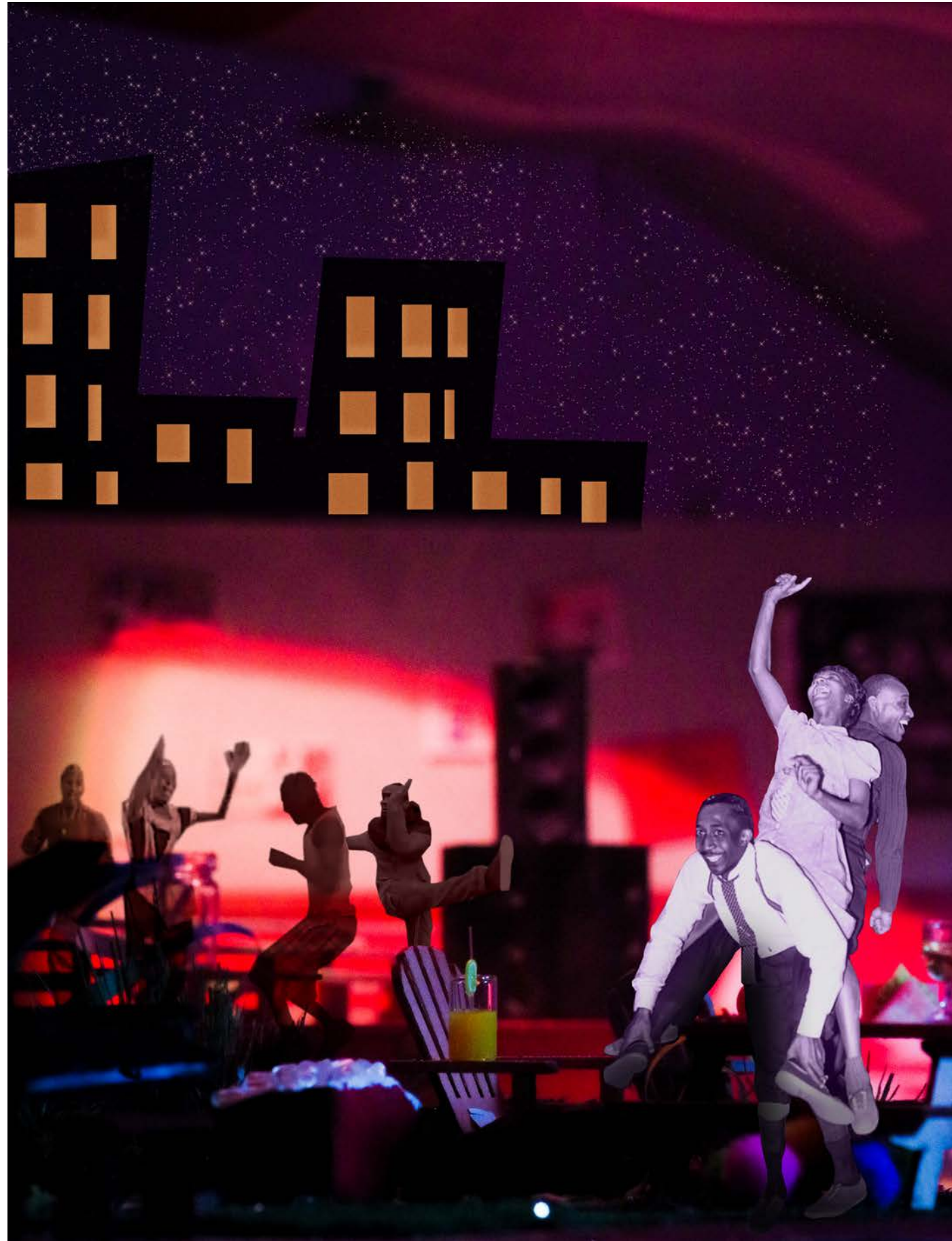

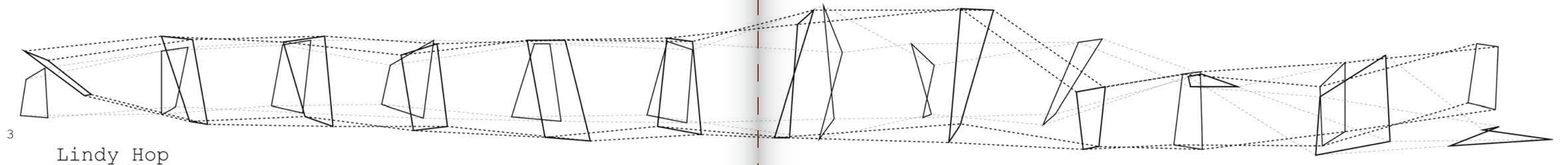
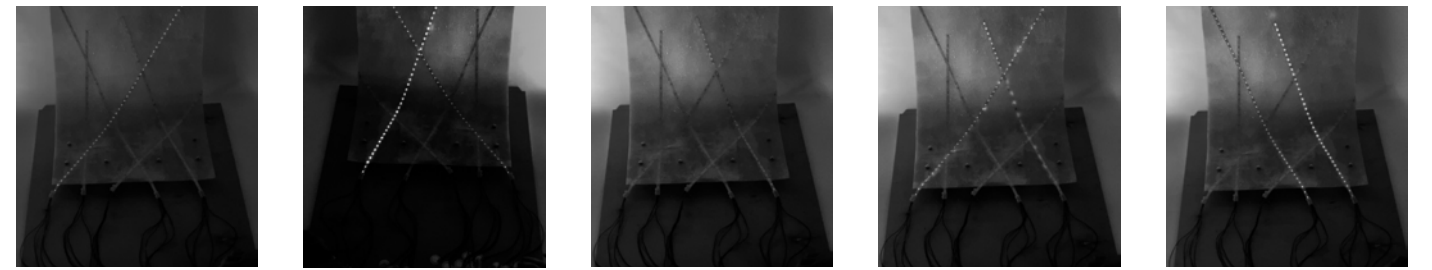

3 Lindy Hop

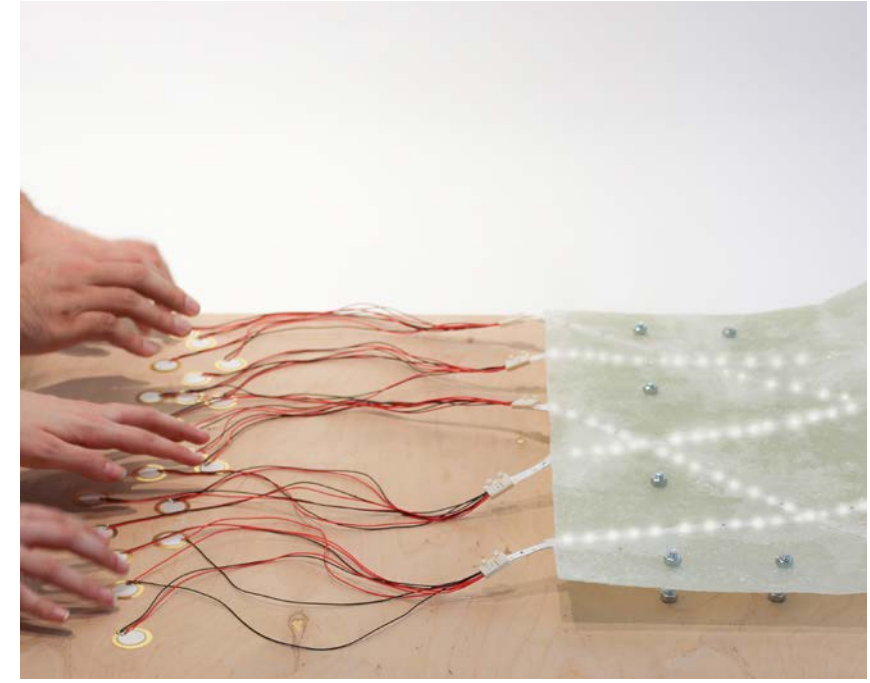
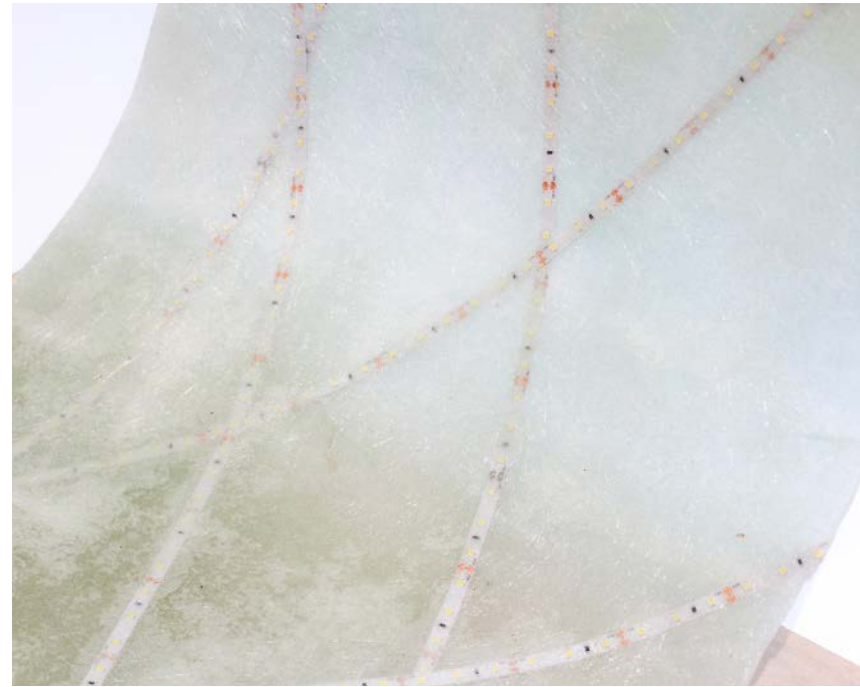
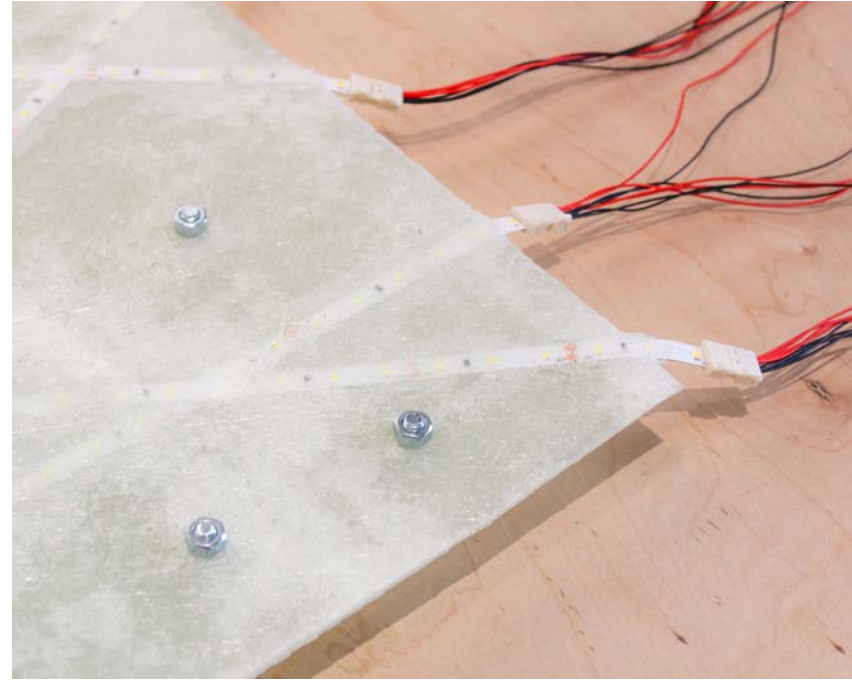

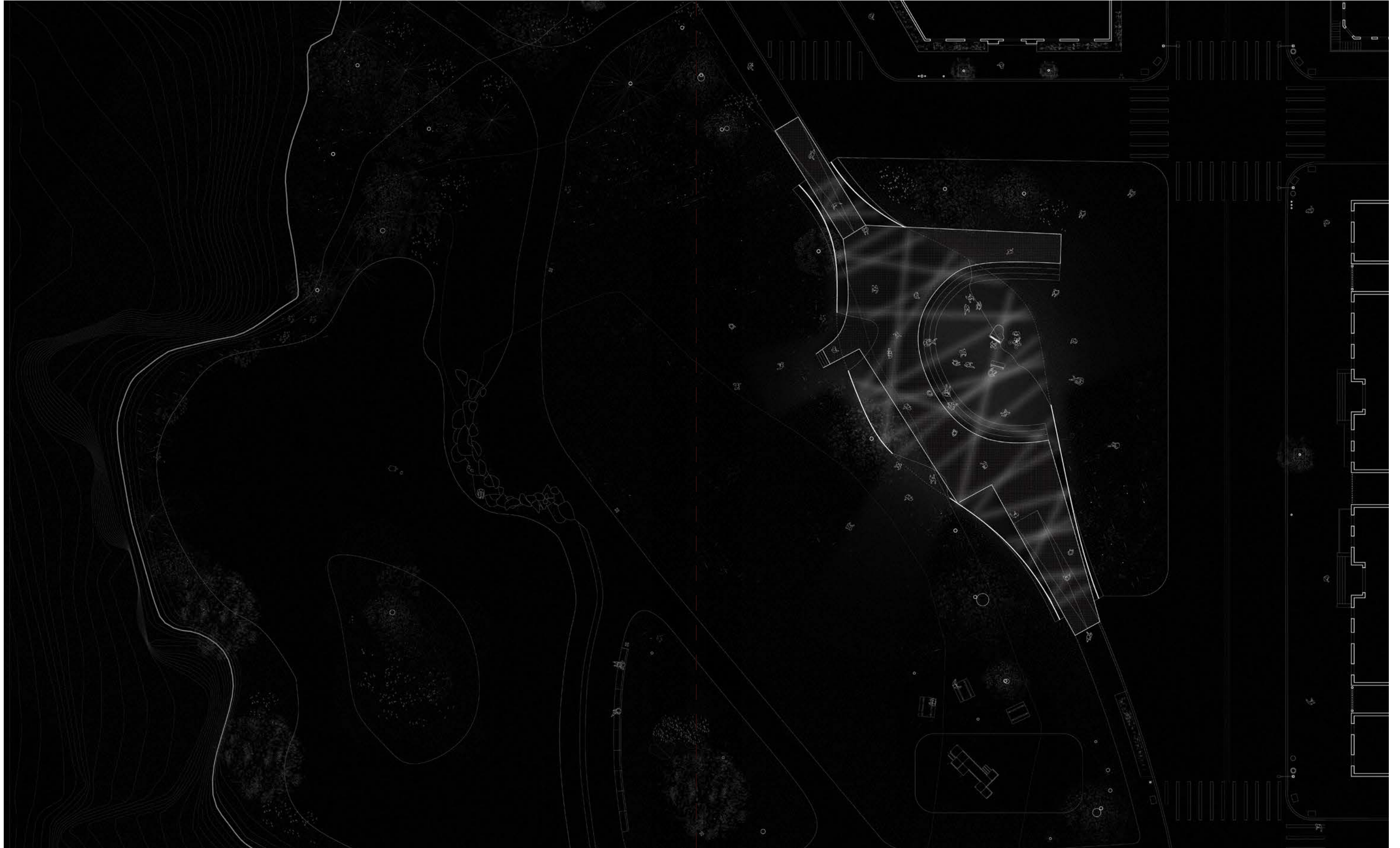



model collage / wall section

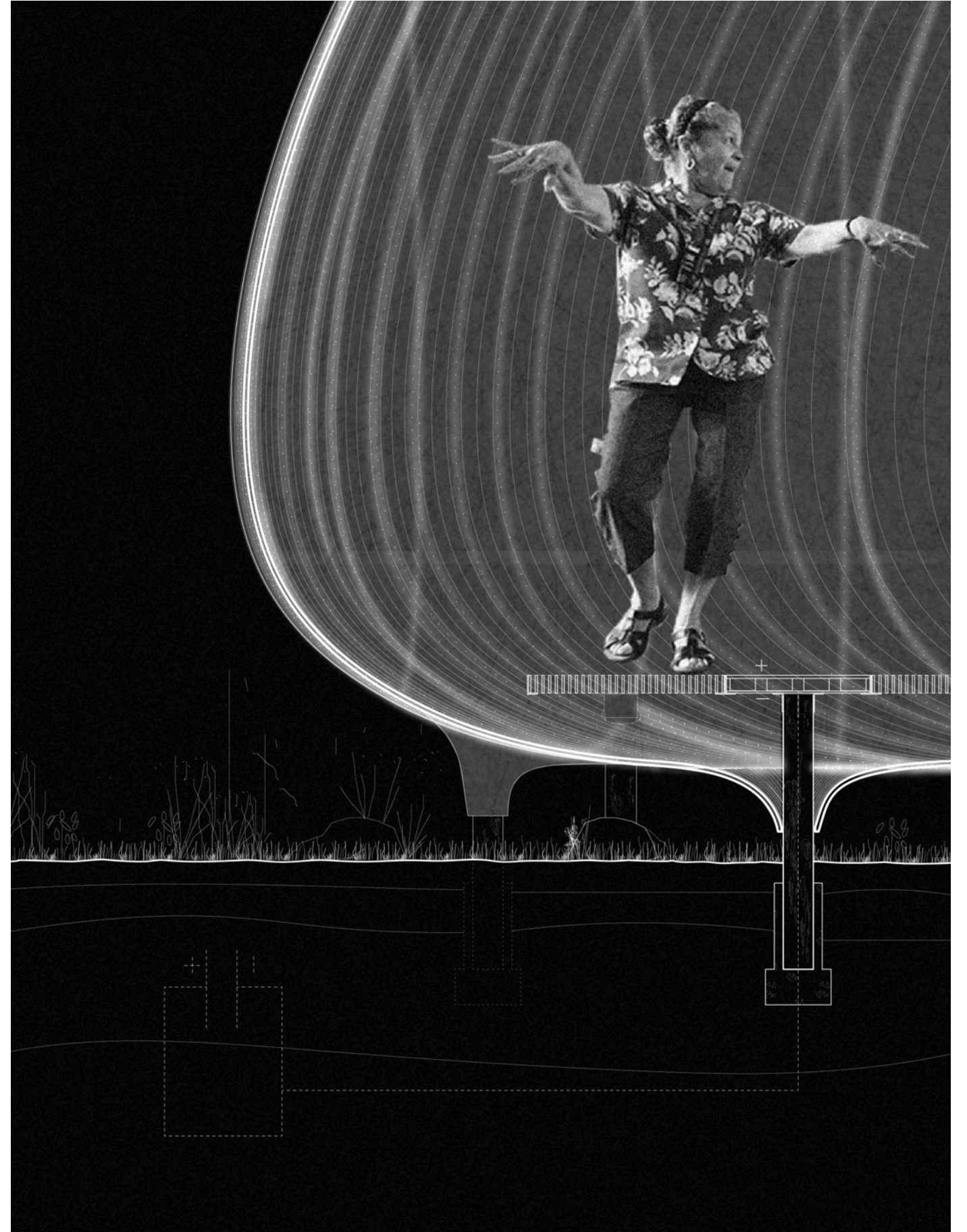

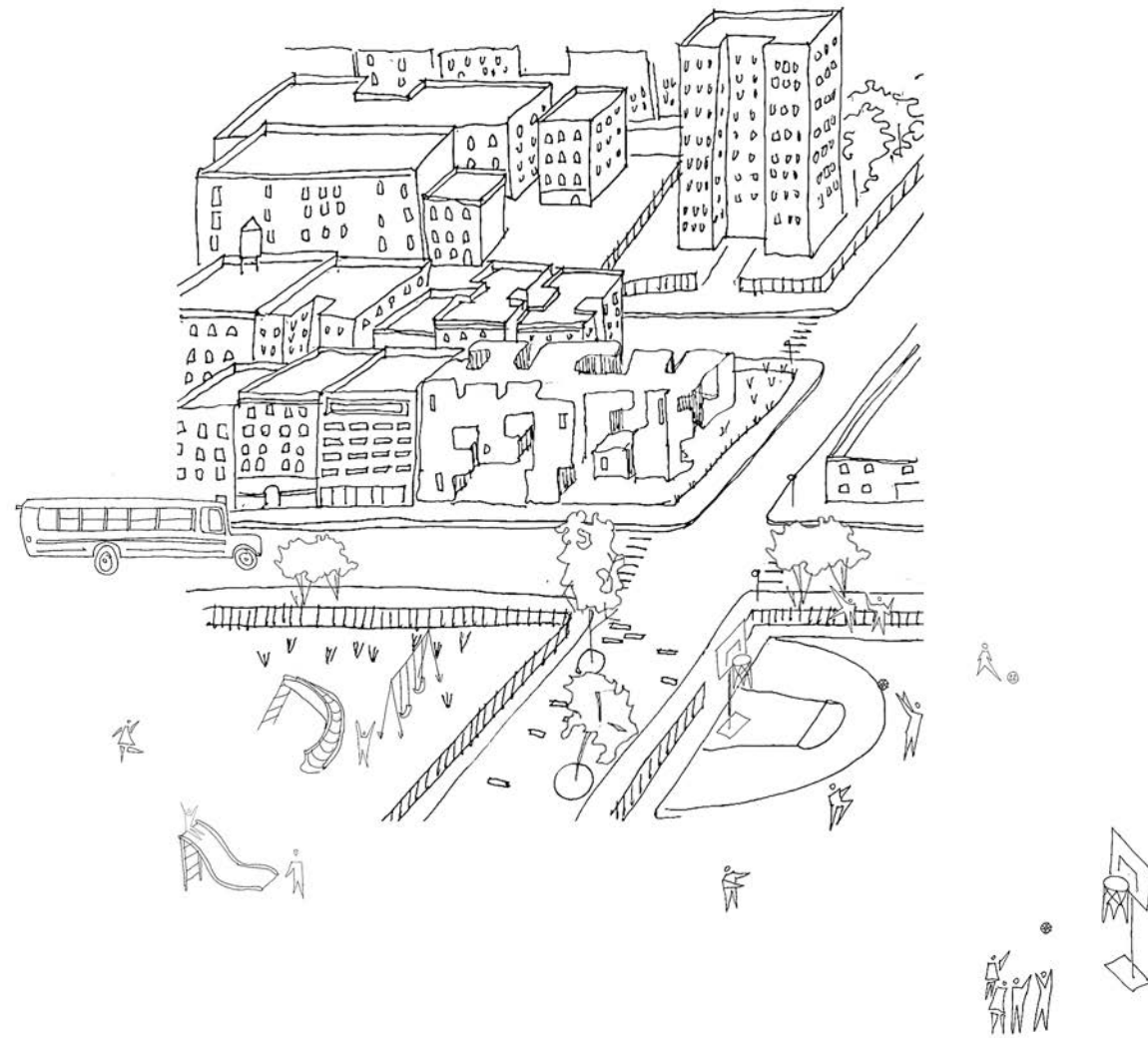

05

x
y
z, school

K-8 School
198 Forsyth St, New York, NY

Professor
Benjamin Cadena

Core II
Spring 2022

The XYZ School uses the school hallway as a basis for its design. The hallway in a normative school is the heart of socialization and brings excitement throughout the monotonous school day.

To not limit these characteristics to just circulation, the hallway merges itself with the classroom. The XYZ School prioritizes movement and activity for modes of learning across the entirety of the building by extending the classroom in the x-y-z direction.

By navigating in three directions, the student's day is not stationary, instead their classes are dispersed throughout a continuous pathway where learning is not limited to just respite but also play and exploration. These classrooms are lifted up from the base of the building that holds the public programs in order to open up the ground floor. As the ground level shifts itself from above to below ground, its roof becomes the turf for a continuous open air play scape.

At XYZ School students are provided a full spectrum of learning experiences, from rest and reflection to high energy play; the mind is exercised in conjunction with the body.



The classroom works in 3 directions, XYZ, to promote continuous movement and activity. Instead of being stagnant in one classroom for the majority of the day. The students explore and wonder to their classes passing through moments of play, study, and rest.

The school extends the park across the street through the ground floor by lifting above and leaving it open to the public.

The school functions on a different time table than typical schools; passing periods are given equal time as classes. Along the way from class to class, students experience modes of activity, connecting spaces for play and high energy, learning study spaces, and at the end points rest spaces.

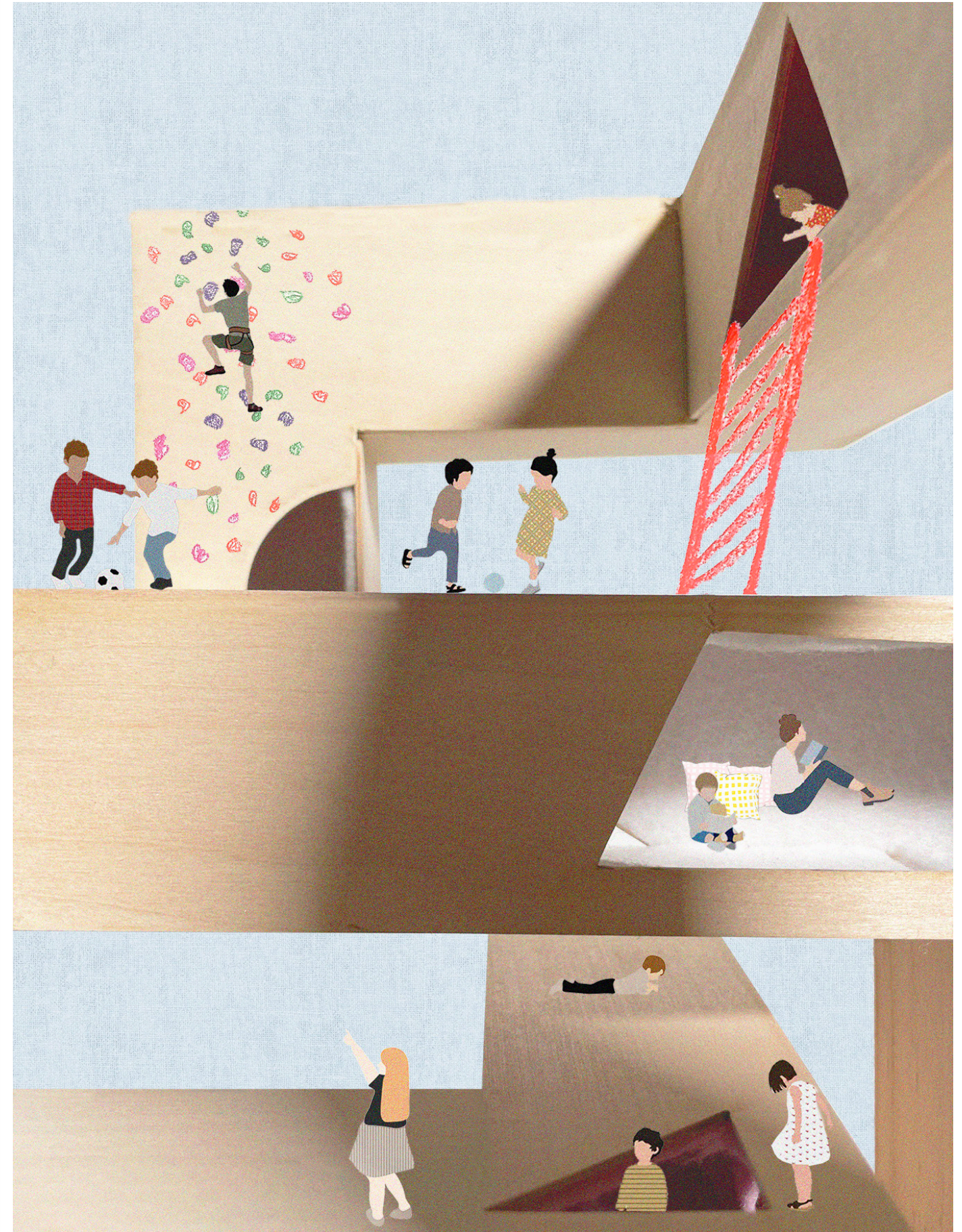

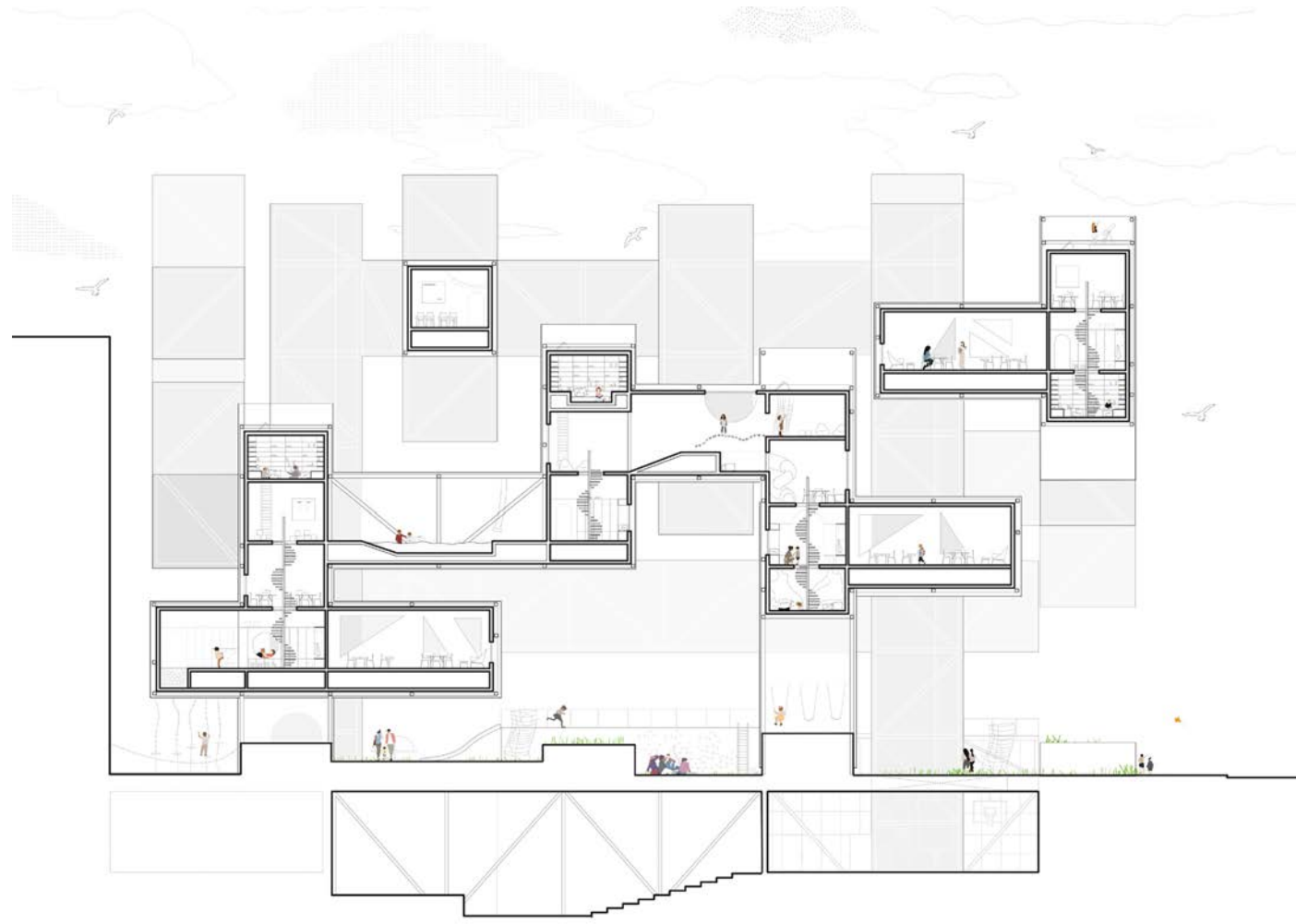

floor plan / section



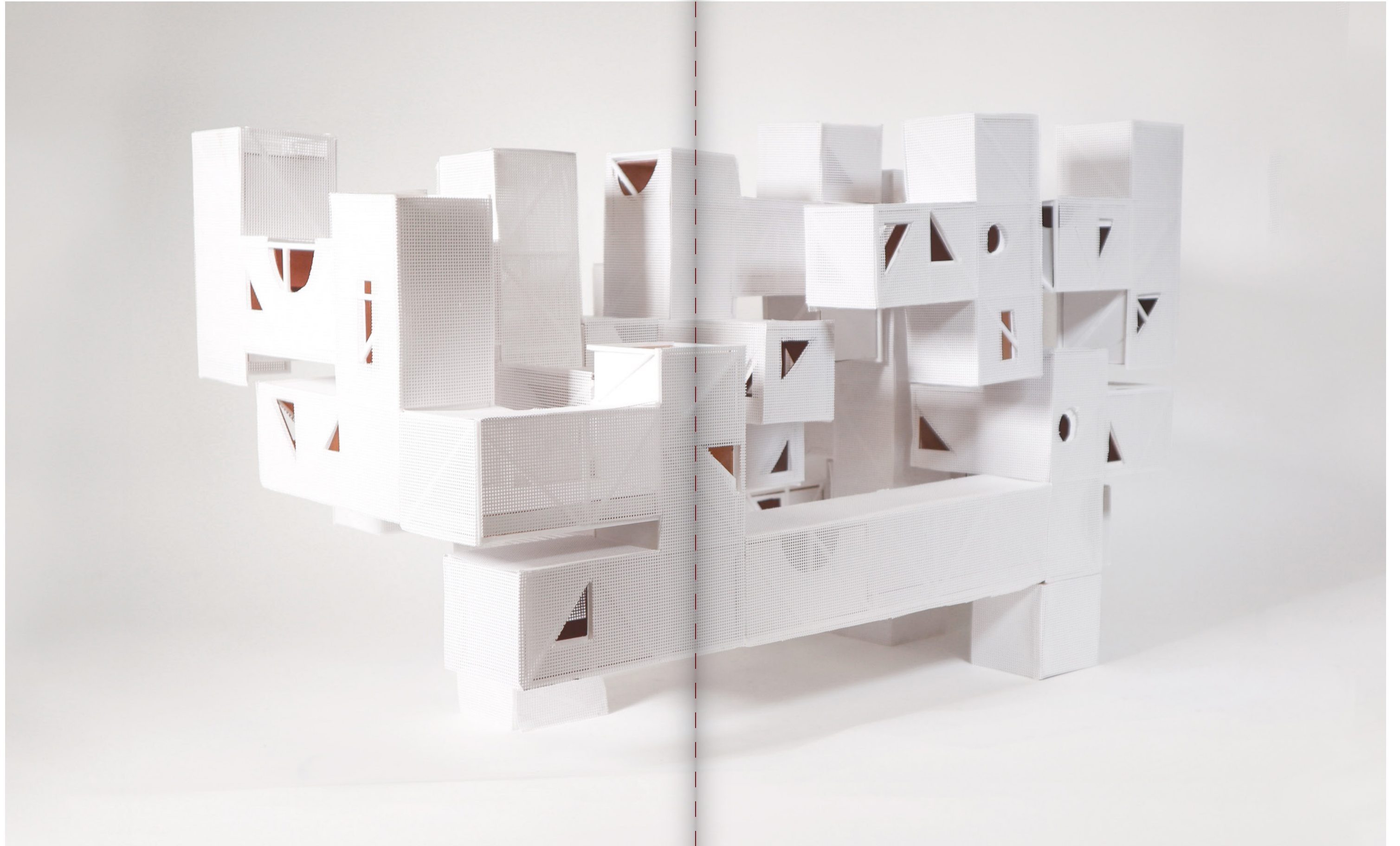



wall section



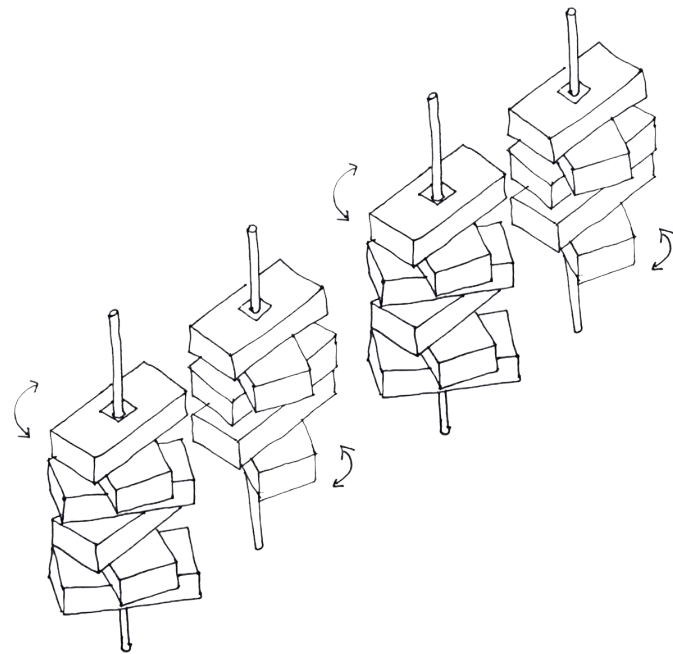

06

Tectonics Of Play

K-8 School
198 Forsyth St, New York, NY

Professor
Berardo Matalucci,
Gabrielle Brainard
Lola Ben Alon

Tech III / IV / V Sequence
Fall 2022 - Spring 2023

In Collaboration with
Key Aiken, Olivia Braun,
Mariam Jacob, Will Coa,
Chris Deegan, Rajvardhan Thorat

The driving concept of "tectonics of play" revolves around the idea of incorporating play directly into the construction of the design. The main wall assembly is a brick veneer system that happens across the entire facade. Breaking up the solid elevation is an operable brick screen that works in two conditions, an exterior patio, and mid door condition. The mid door condition utilizes a Nana wall set inside the operable brick screen. Therefore, on a nice day, with the Nana wall fully open, the space feels completely outdoor.

Inversely, on a rainy or cold day, with the Nana wall fully closed, it marks the building's line of enclosure. Each brick can be spun around and played with, emulating devices consistent with playgrounds, while still maintaining a protective rail across the facade. The project merges the building system across different scales to reinforce a school that prioritizes play, daylight, and fresh air.

Studying the construction ecology of this system, the project evolved into a wood screen, offering the same benefits but with deeper considerations to the buildings carbon footprint. This evolved into a half scale model that mocks up the wall assembly.

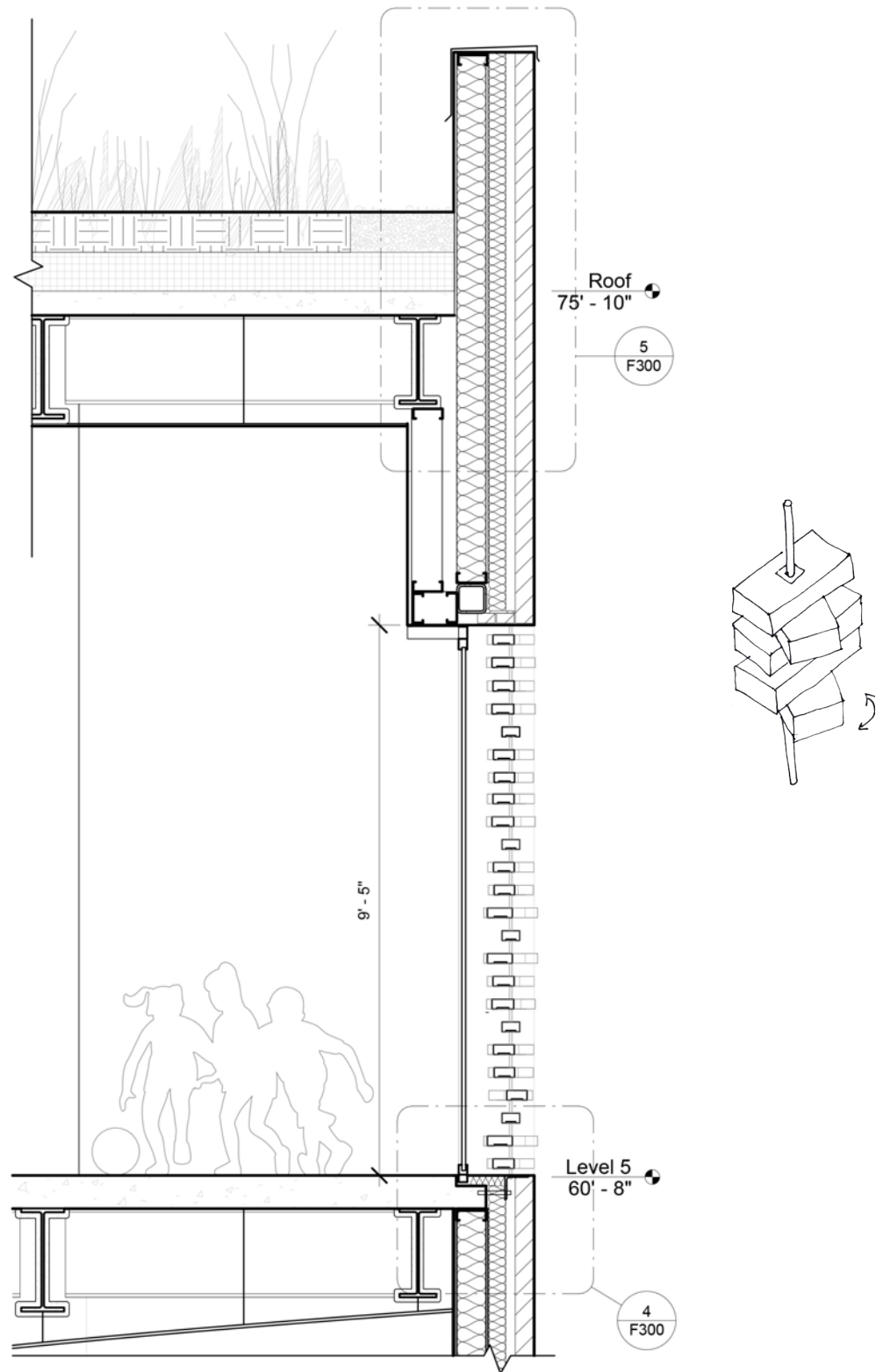

wall section

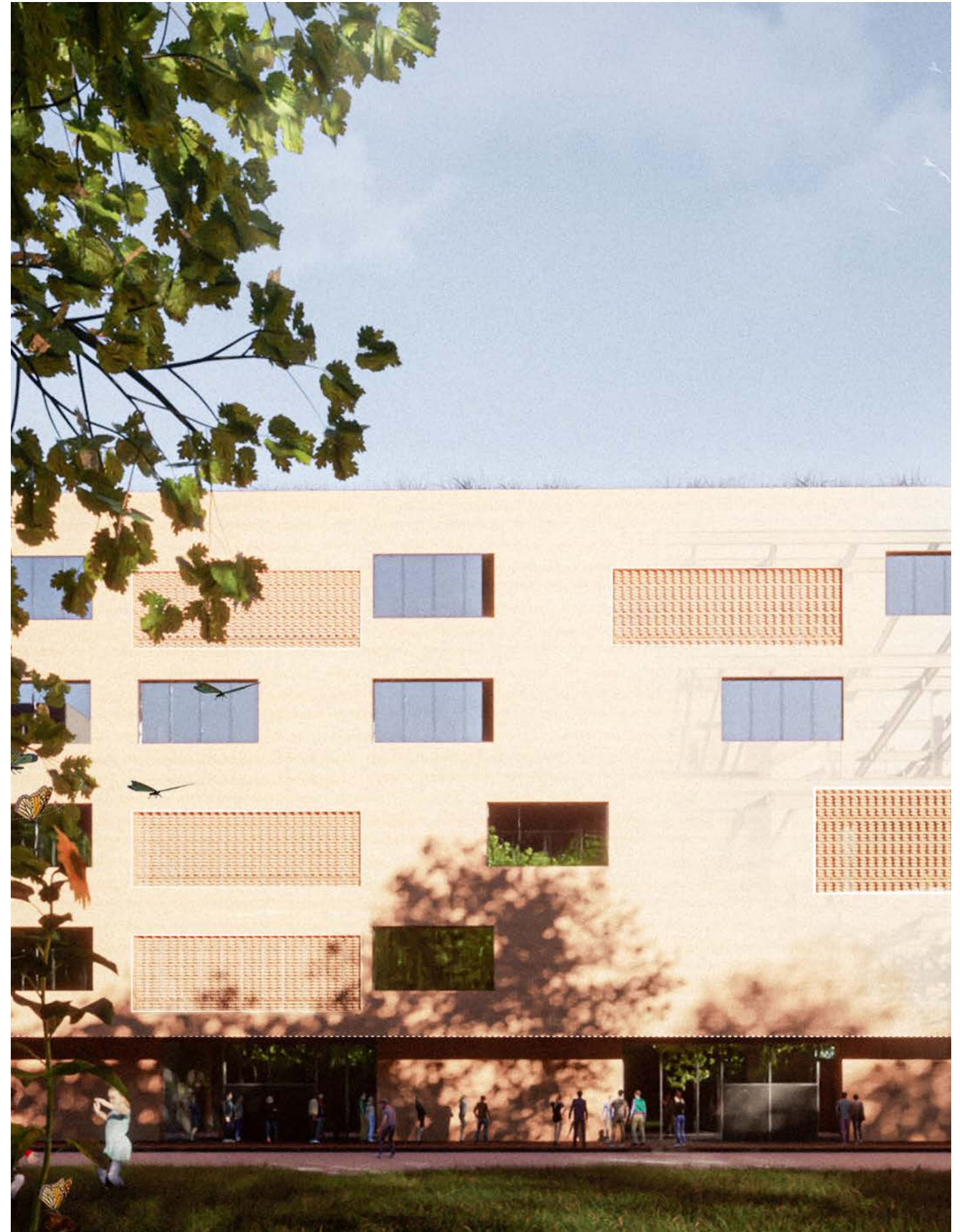

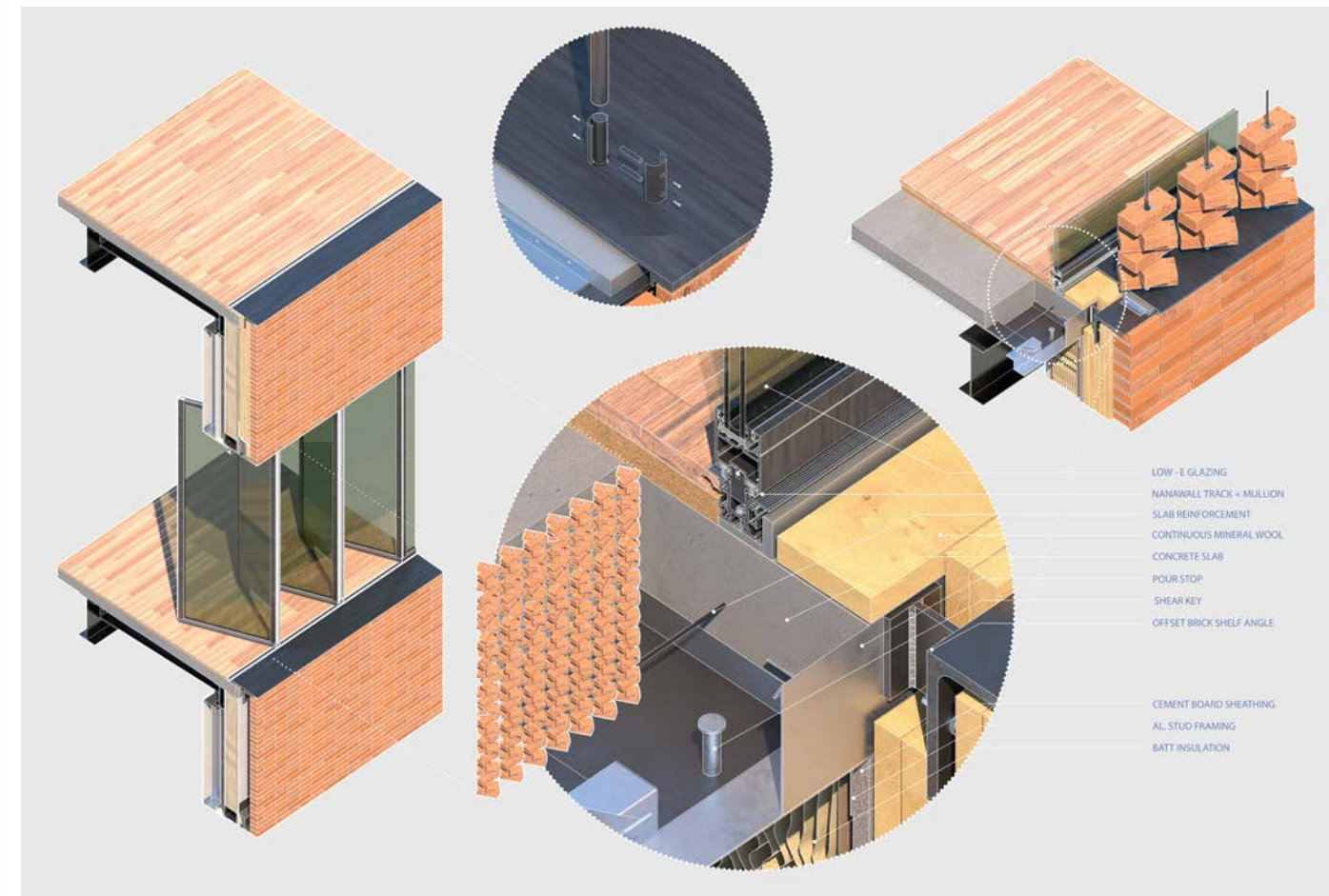
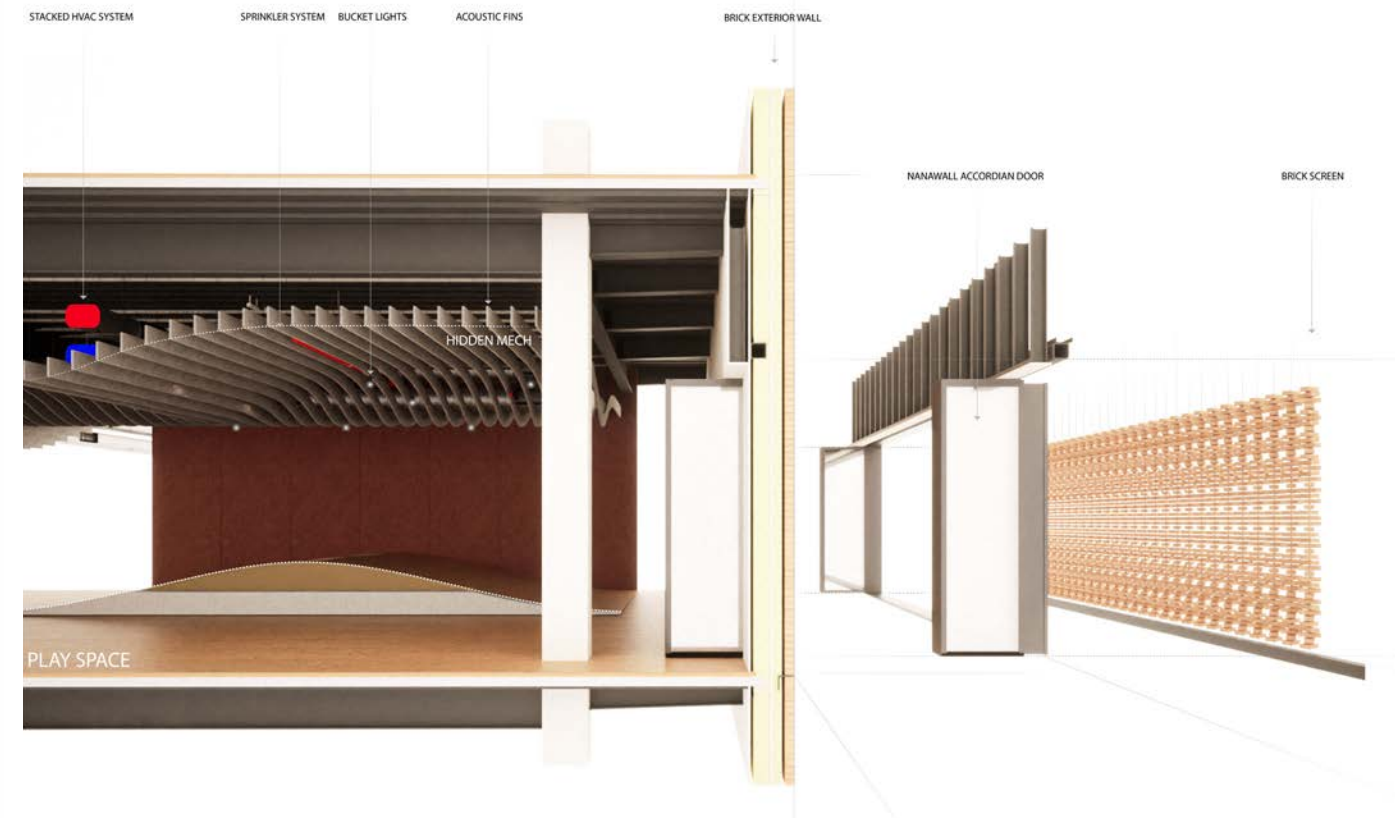
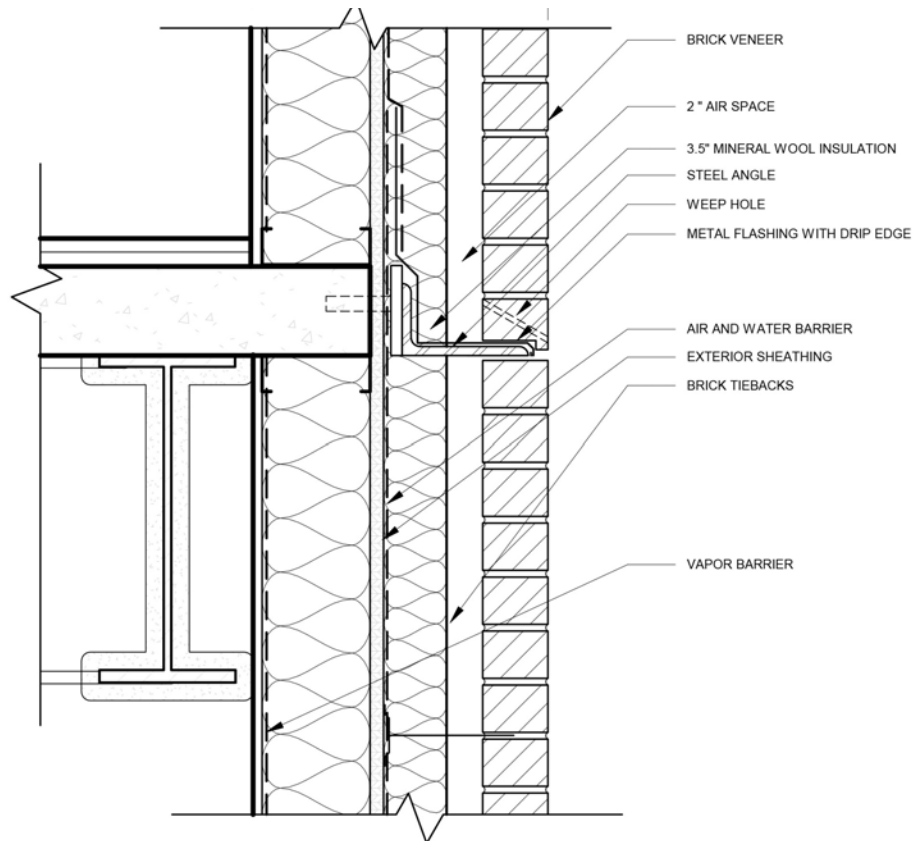
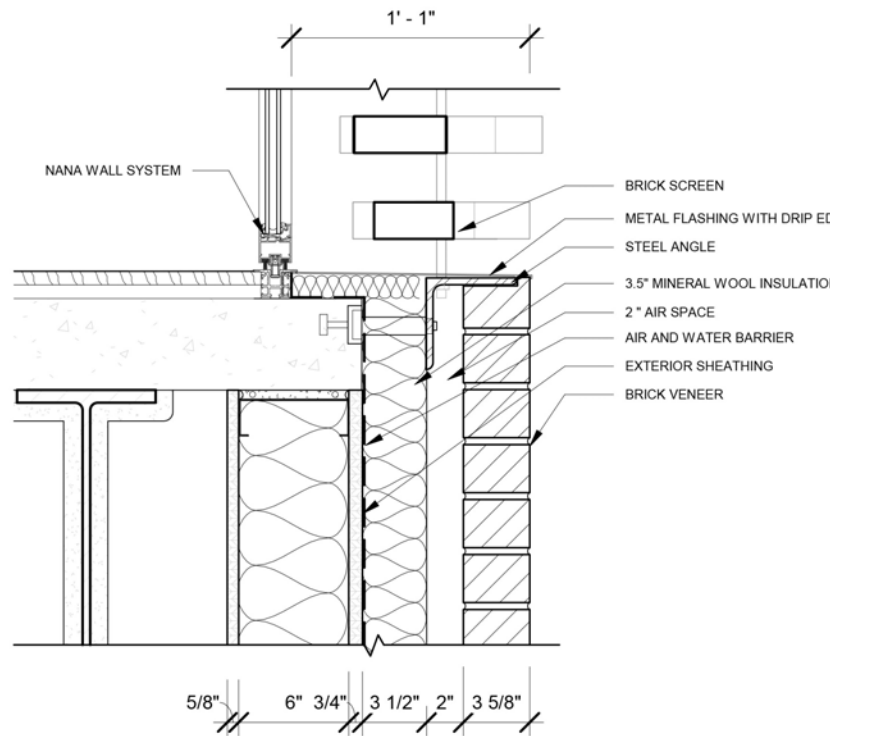

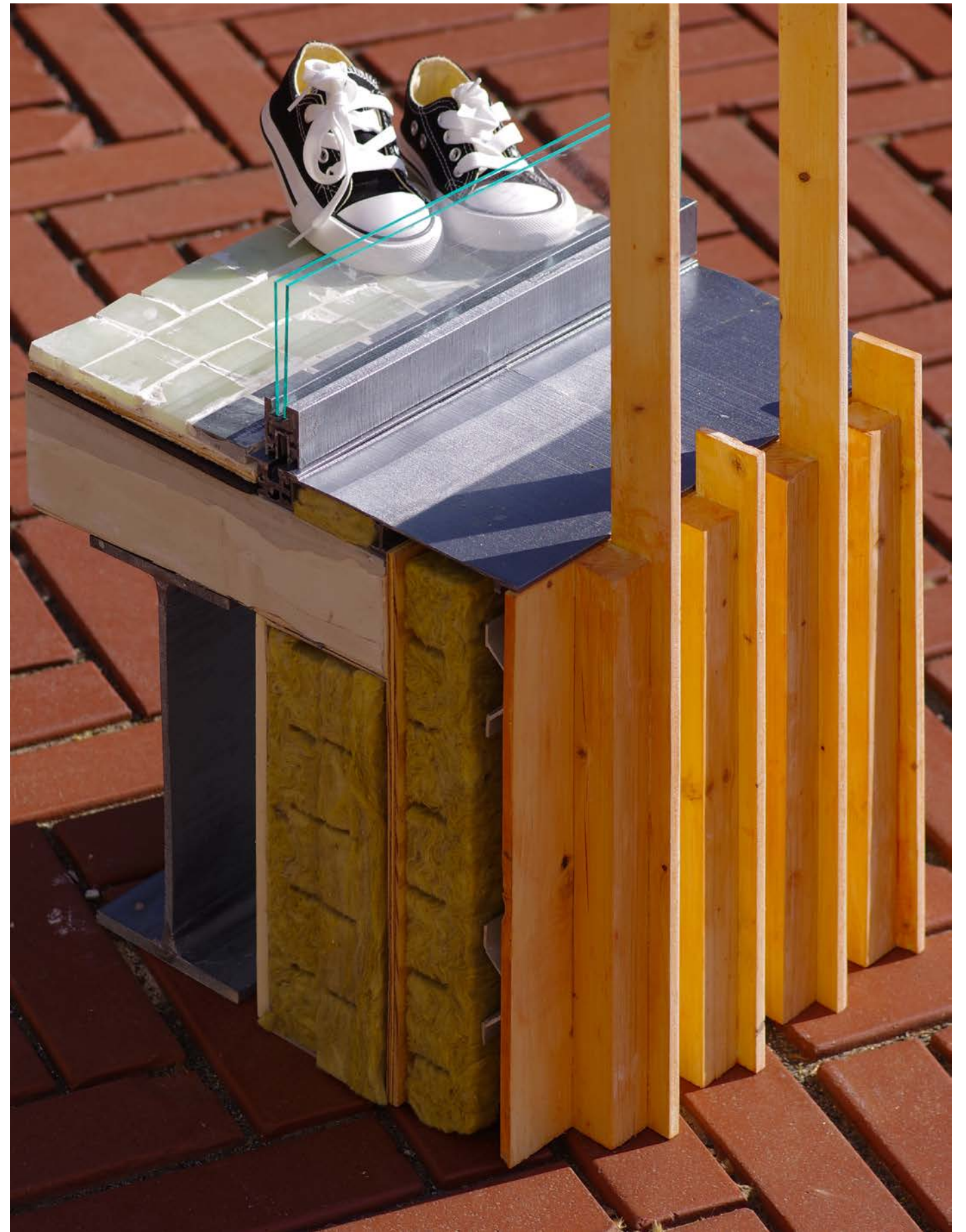
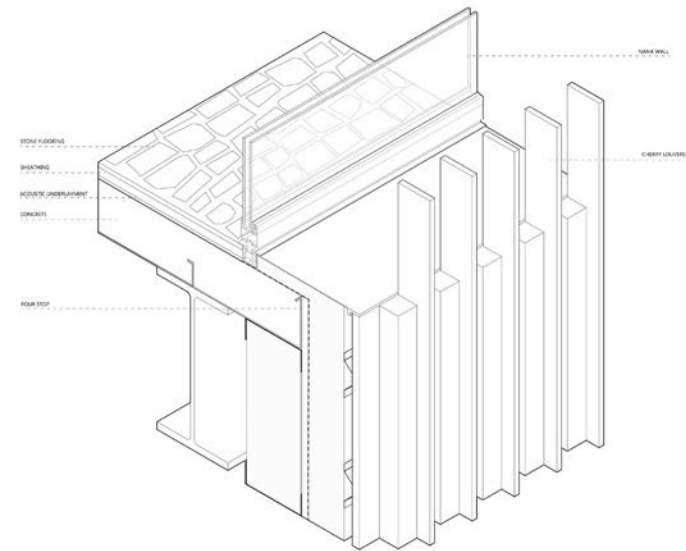
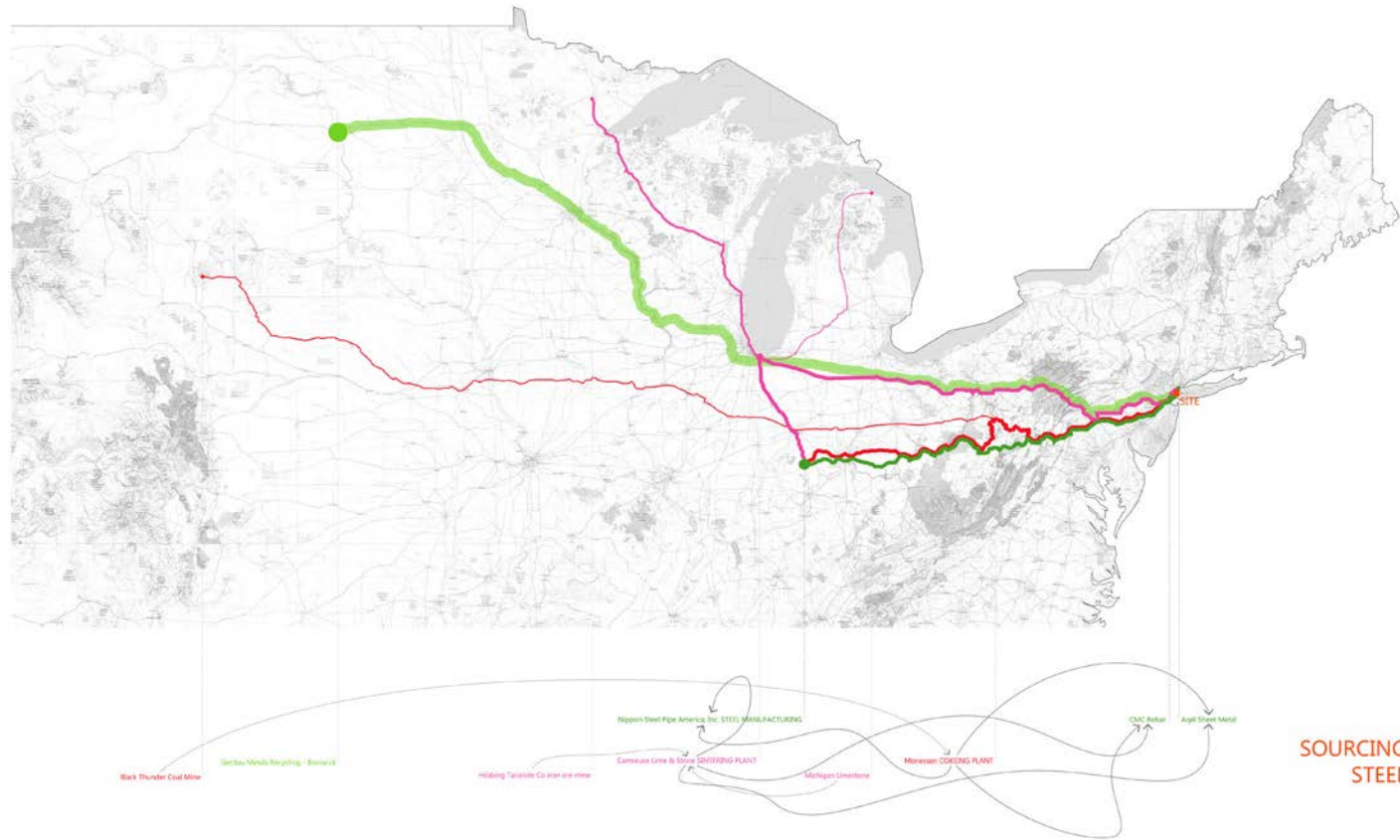

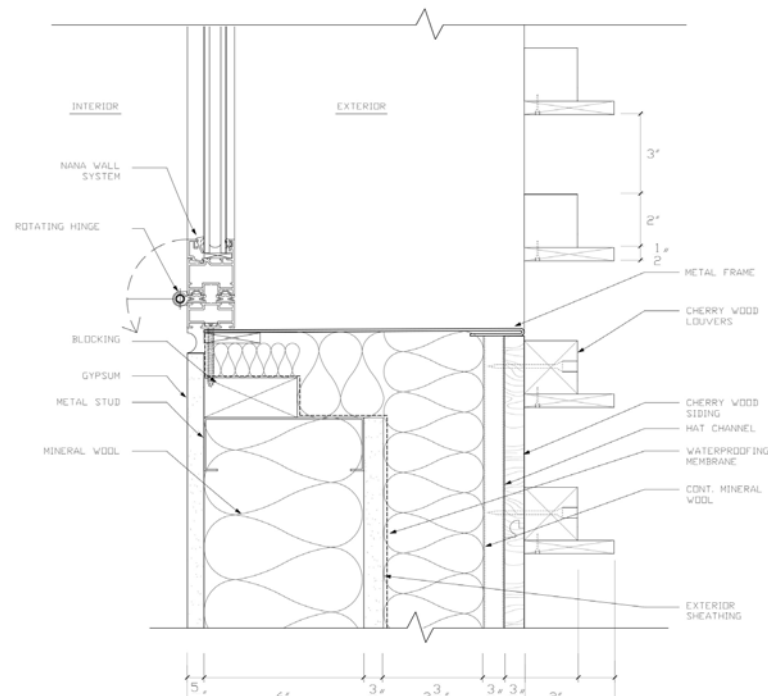
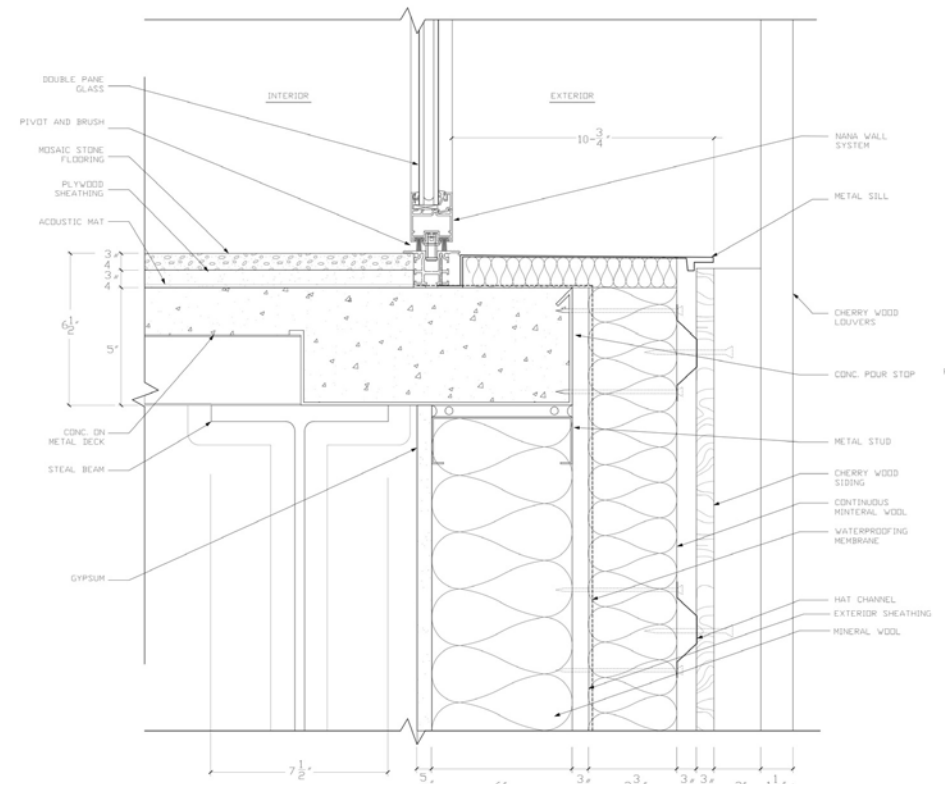

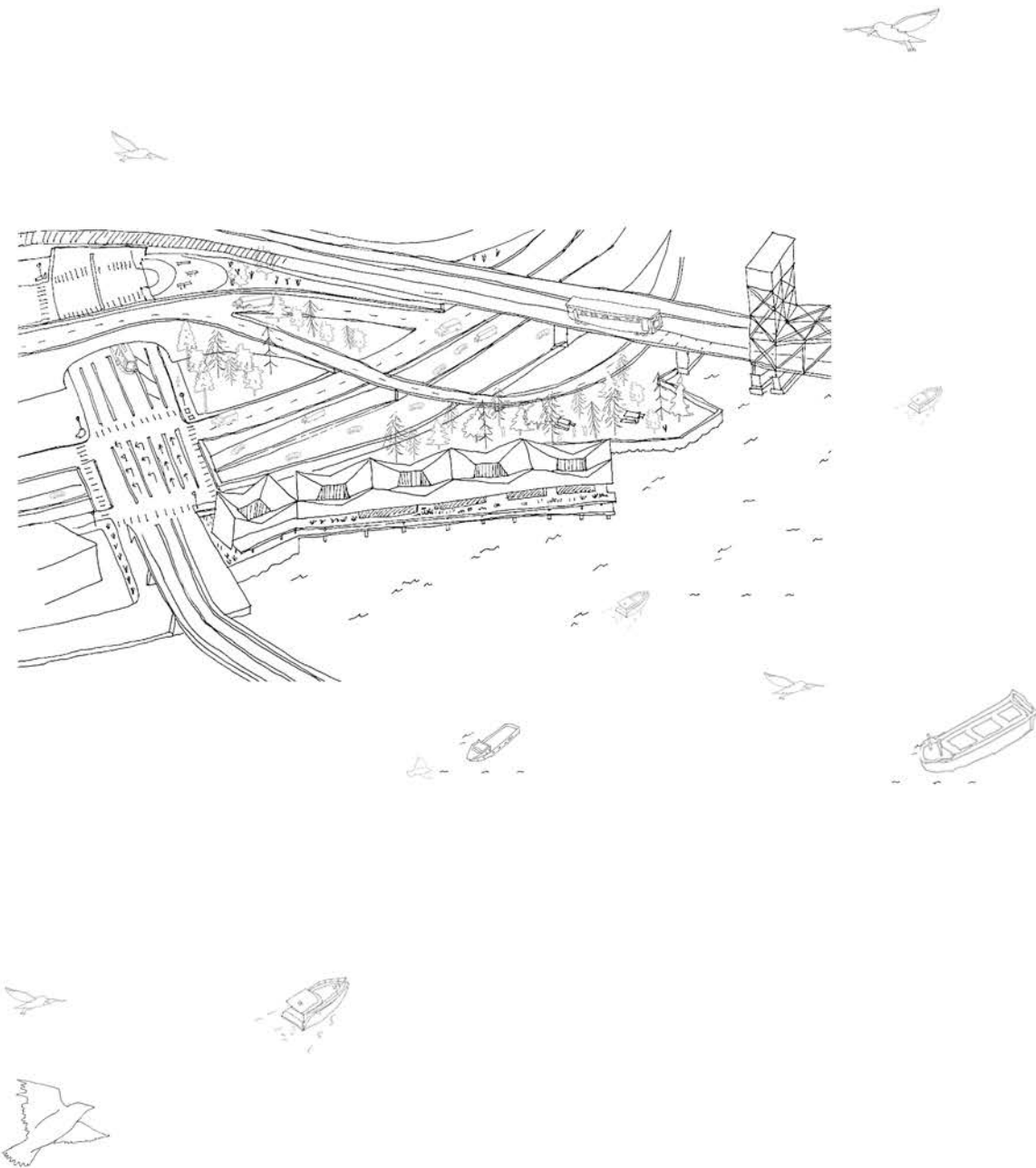

07 Under One Roof

Housing For Women
and Children; DV Shelter
163 Exterior Street, Bronx, NY

Professor
Erica Goetz

Core III
Fall 2022

In Collaboration with
Olivia Braun

ft. Grid Garden

Professor
Emily Bauer

Tech Elective - Seed Bombs
Fall 2023

In Collaboration with
Olivia Braun

Under One Roof serves as a domestic violence shelter out of necessity due to the increased cases in the Bronx. DV is also the leading cause for homelessness for women and children. Located along the Harlem River, the project utilizes the water for healing qualities for its residents. The form is established for water collection, producing an inward pitched roof. However the slope is increased to make it an inhabitable loft-like space, hosting the private, inward looking sleeping chambers. These spaces offer a small, intimate room for residents to rest and retreat.

In contrast to the solidity of the sleeping level, the descending living and community floors operate in layers of both privacy and operability. The layers of the envelope compress and expand planimetrically to create a variety of conditions both interior and exterior that respond to the natural environment and the weather. The intention here is to blur the line between inside and outside, and reconnect the residents to the natural world where the beauty of the river can be brought into the building. Through weaving and wrapping the building with these skins, they act as a connective tissue that links the building to its environment, selectively allowing in breeze, sunlight, or even misty rain.

Under One Roof reclaims the salt marsh that existed along the Harlem River before industrialization radically transformed the water's edge. The project has a duality in which it attempts to heal the river and ecosystem surrounding it, while also heal the residents from past trauma. The site in its current condition is strangled by interstates and railways. The proposed plan gives more land back to the water, and utilizes its closed off condition for privacy and protection of the residents. The most public node of the project, an immediate care clinic anchors the corner while the more private residential program splinters off into the water.



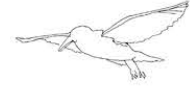

b



c

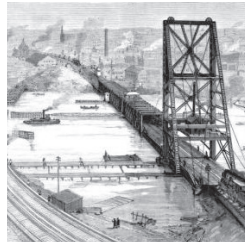

d

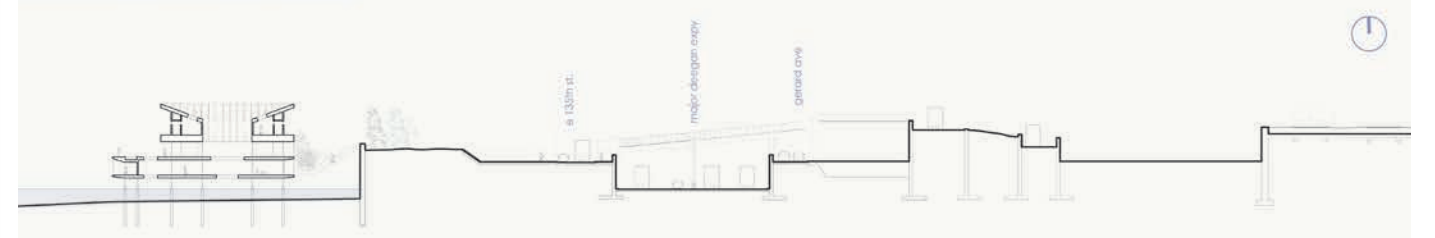
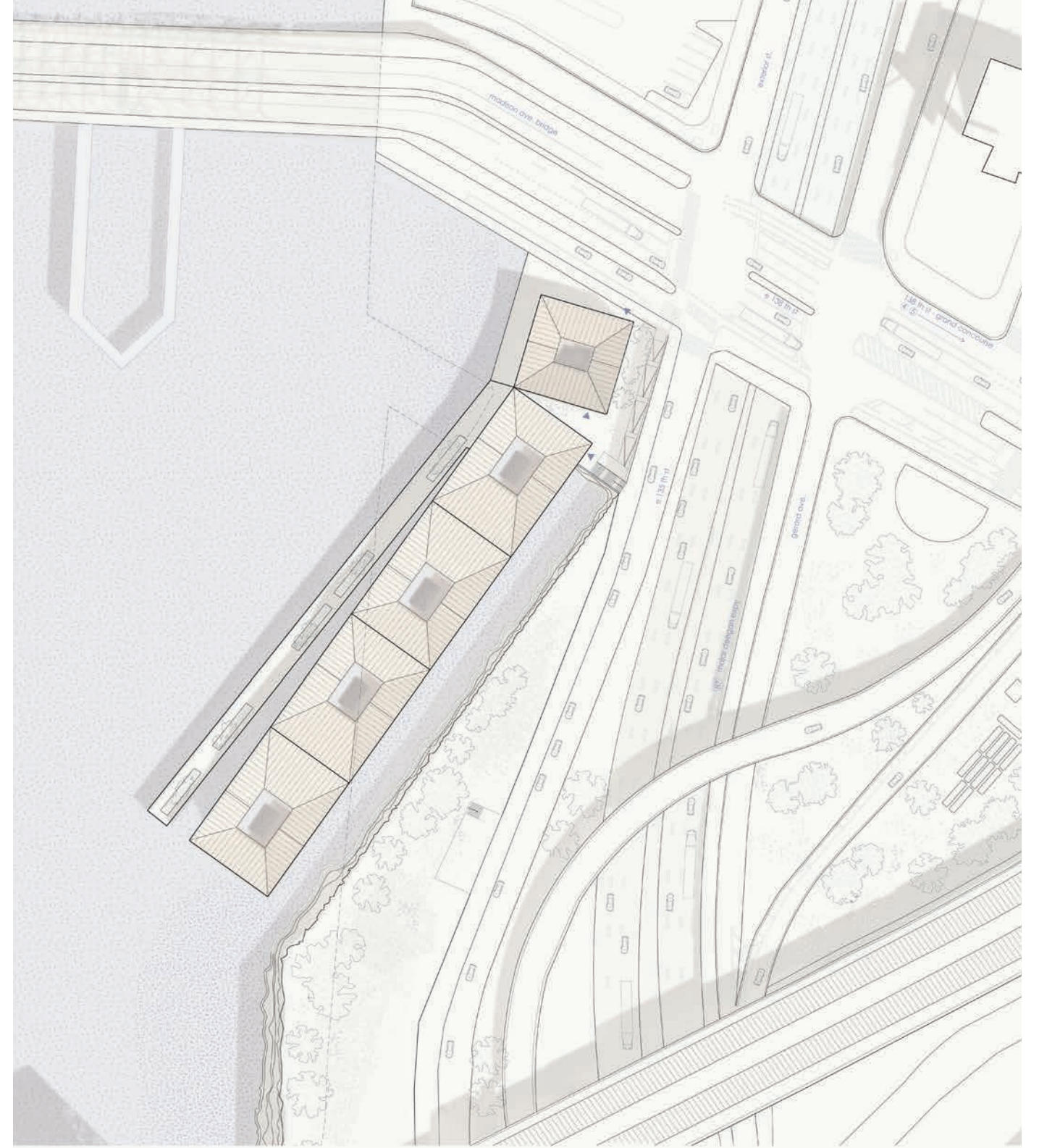

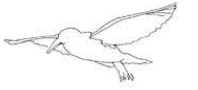
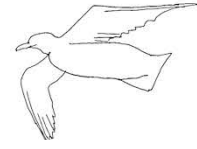
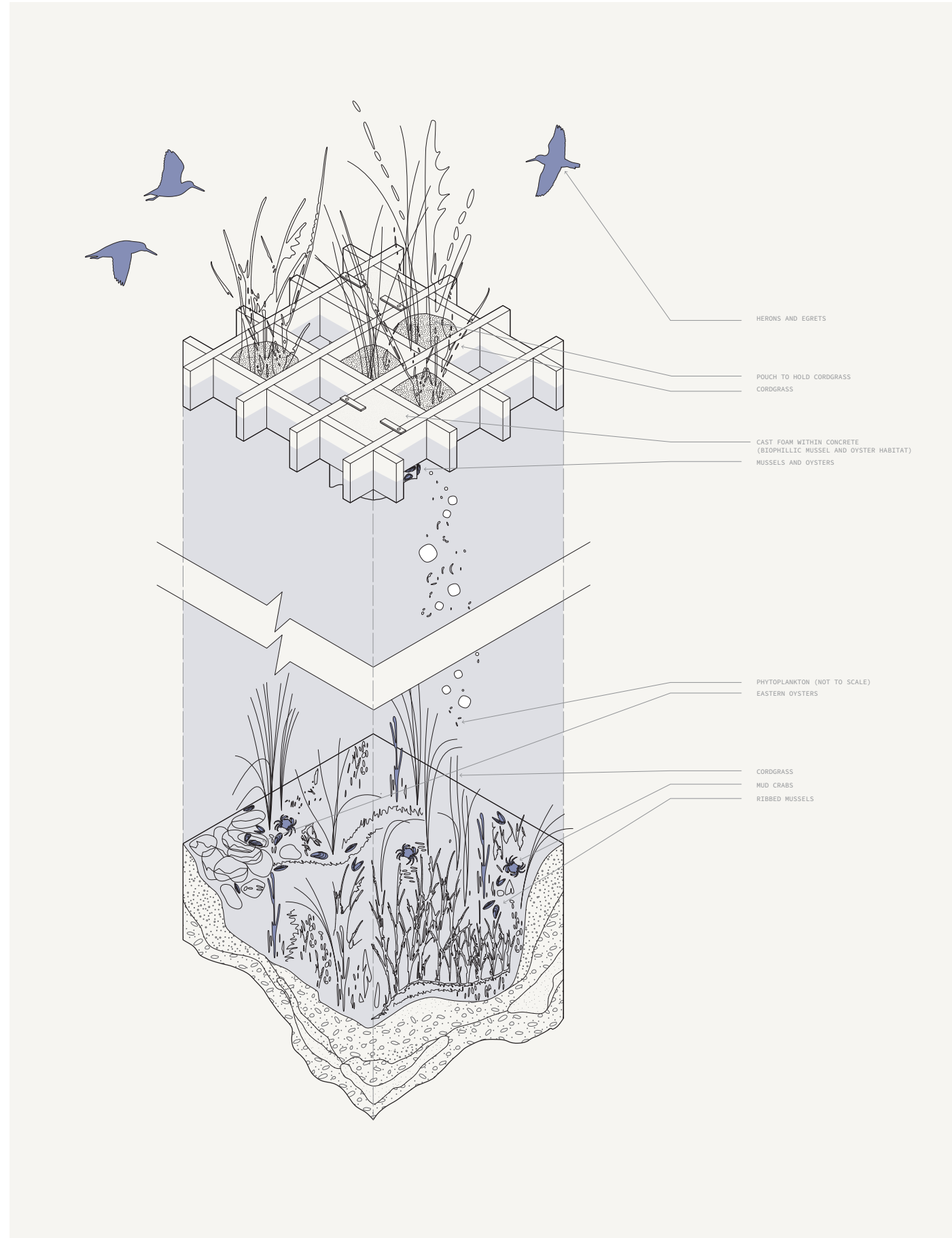

wall section

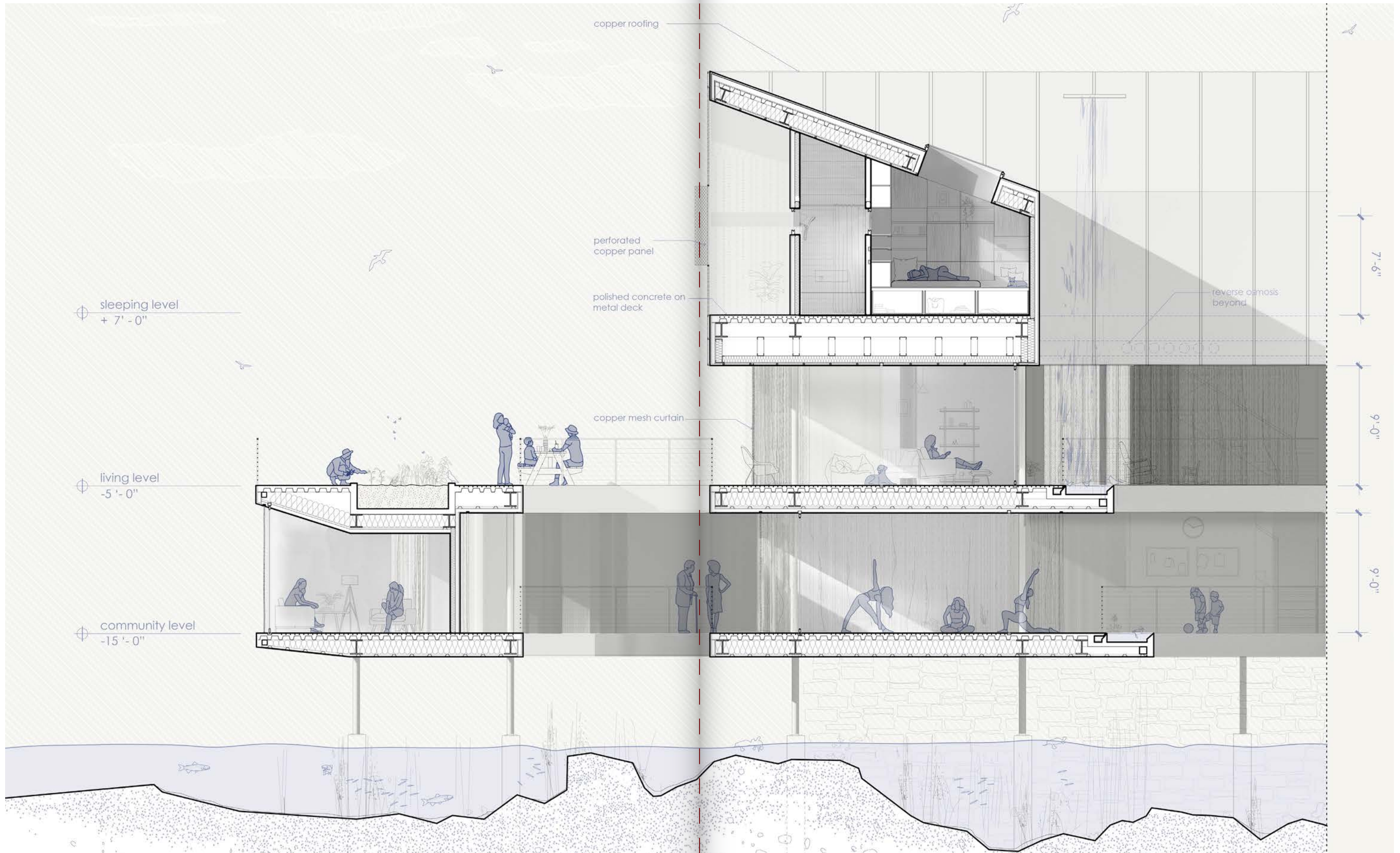

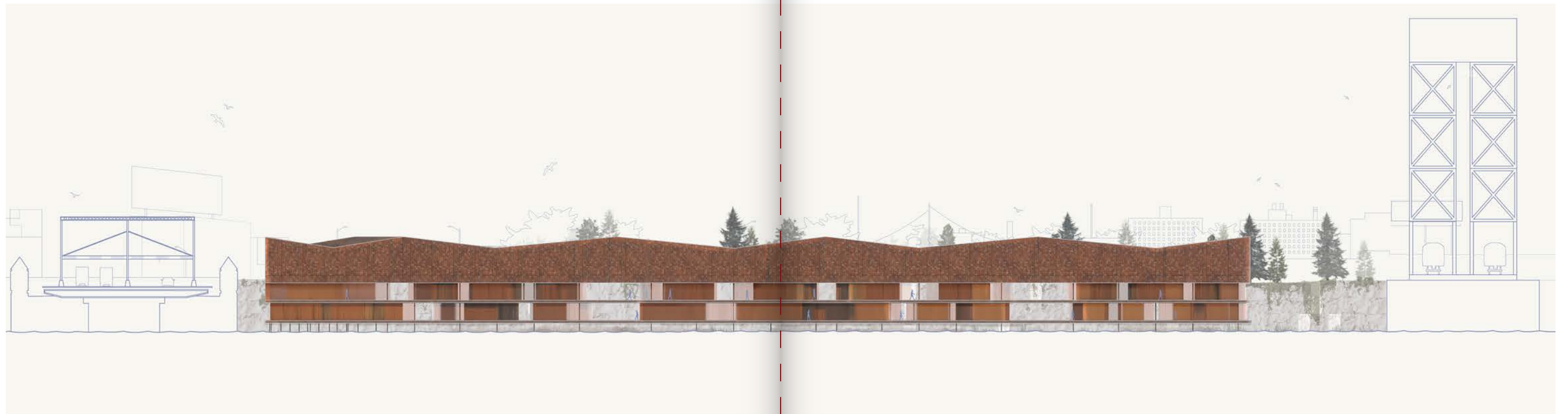
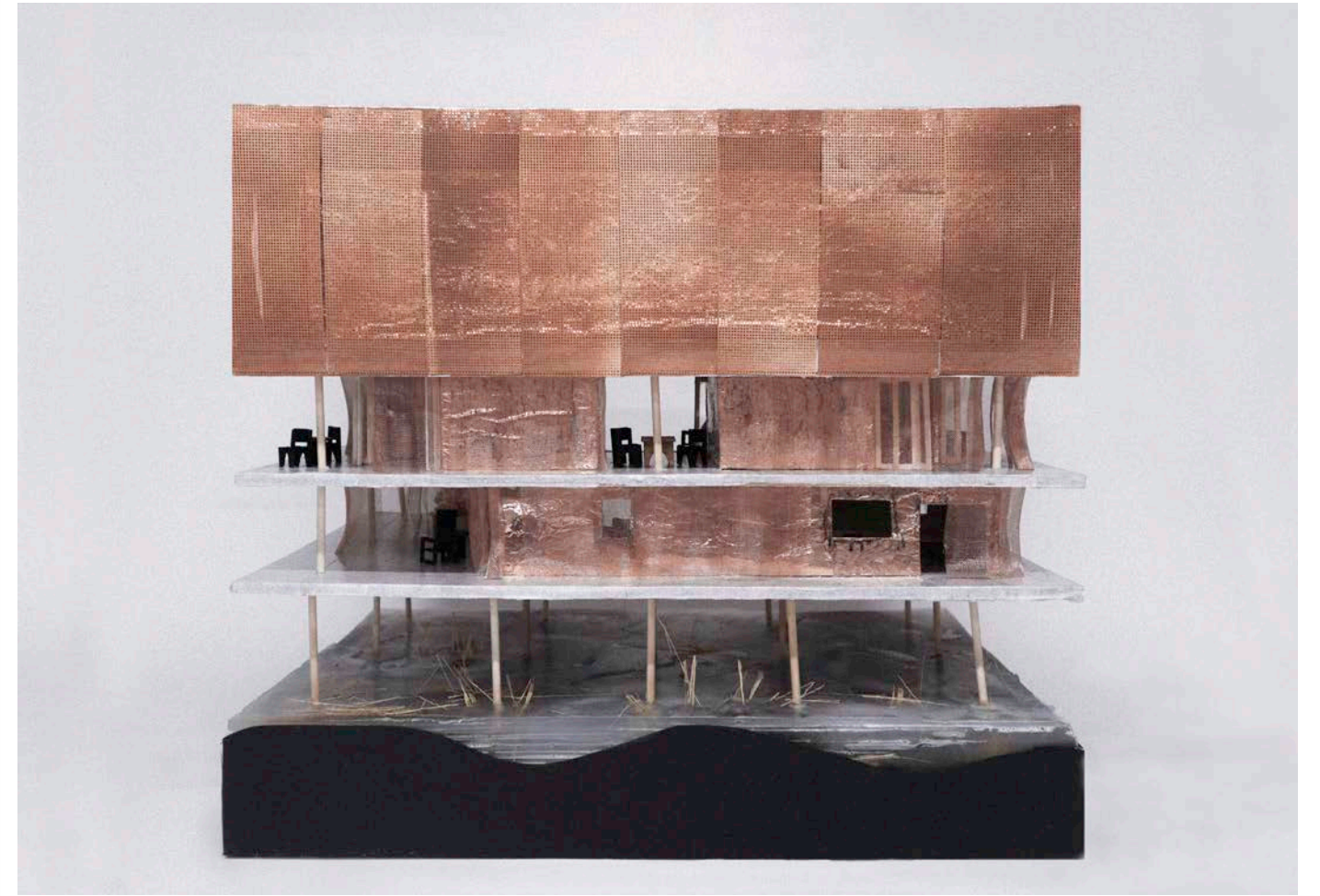
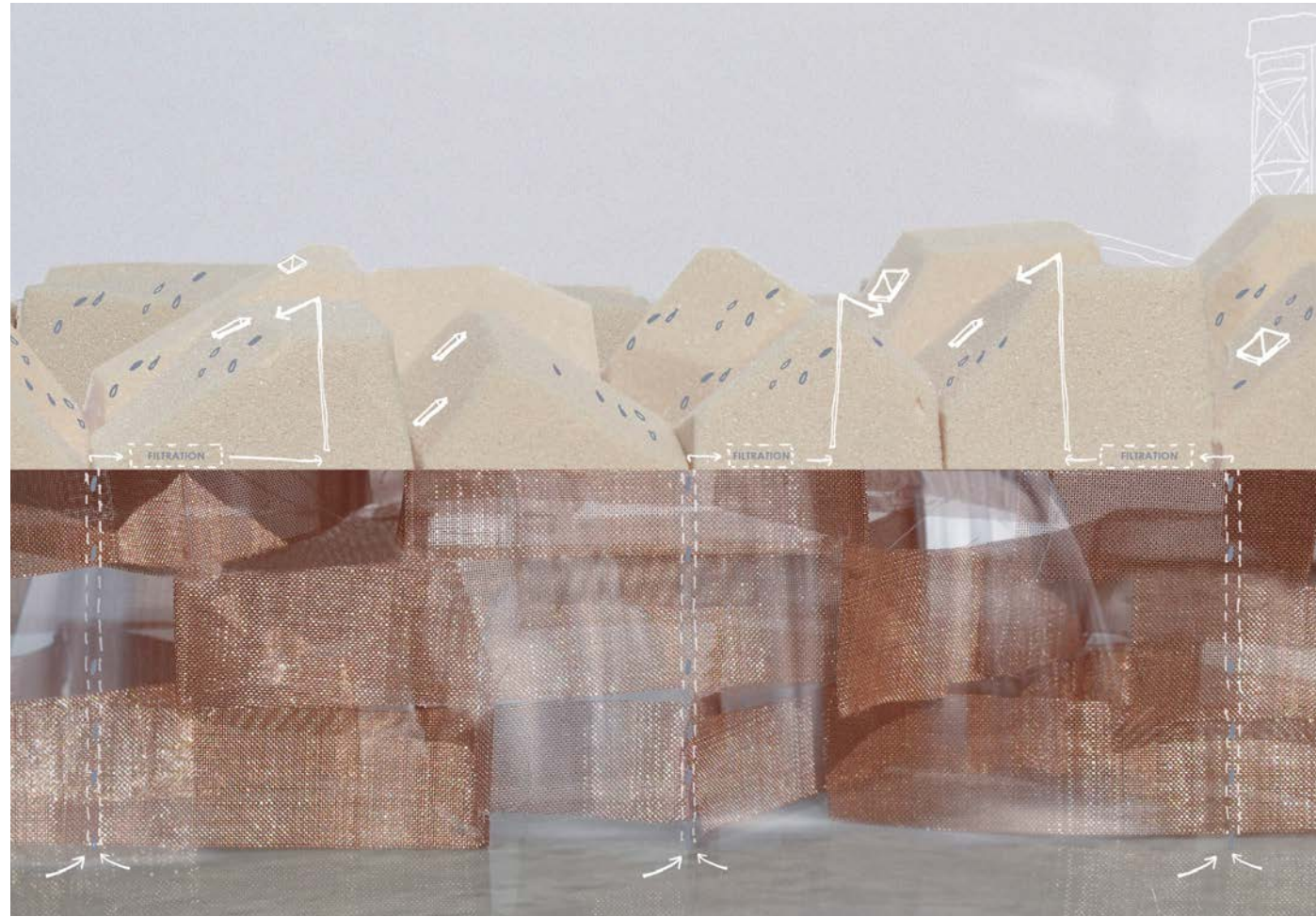

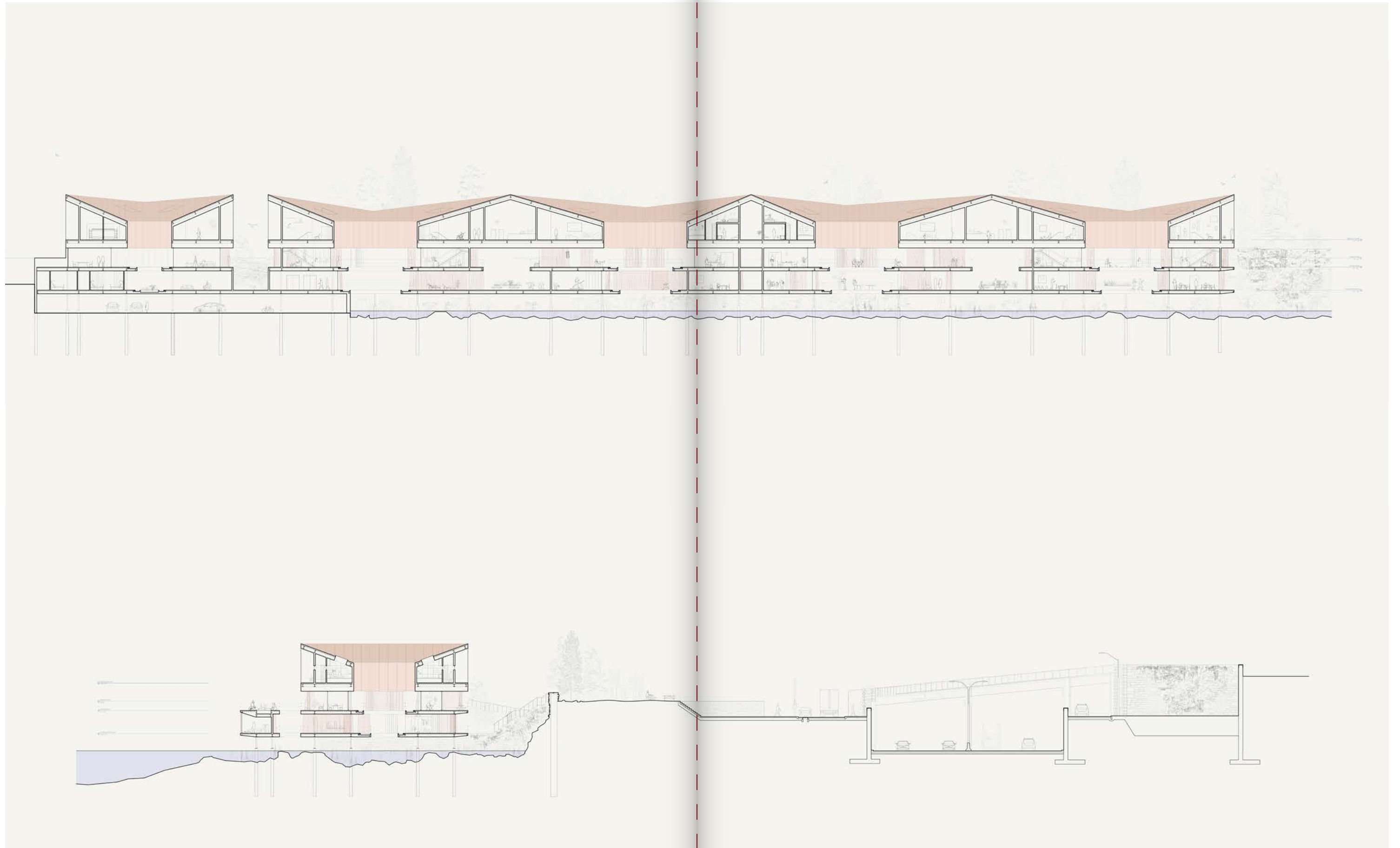

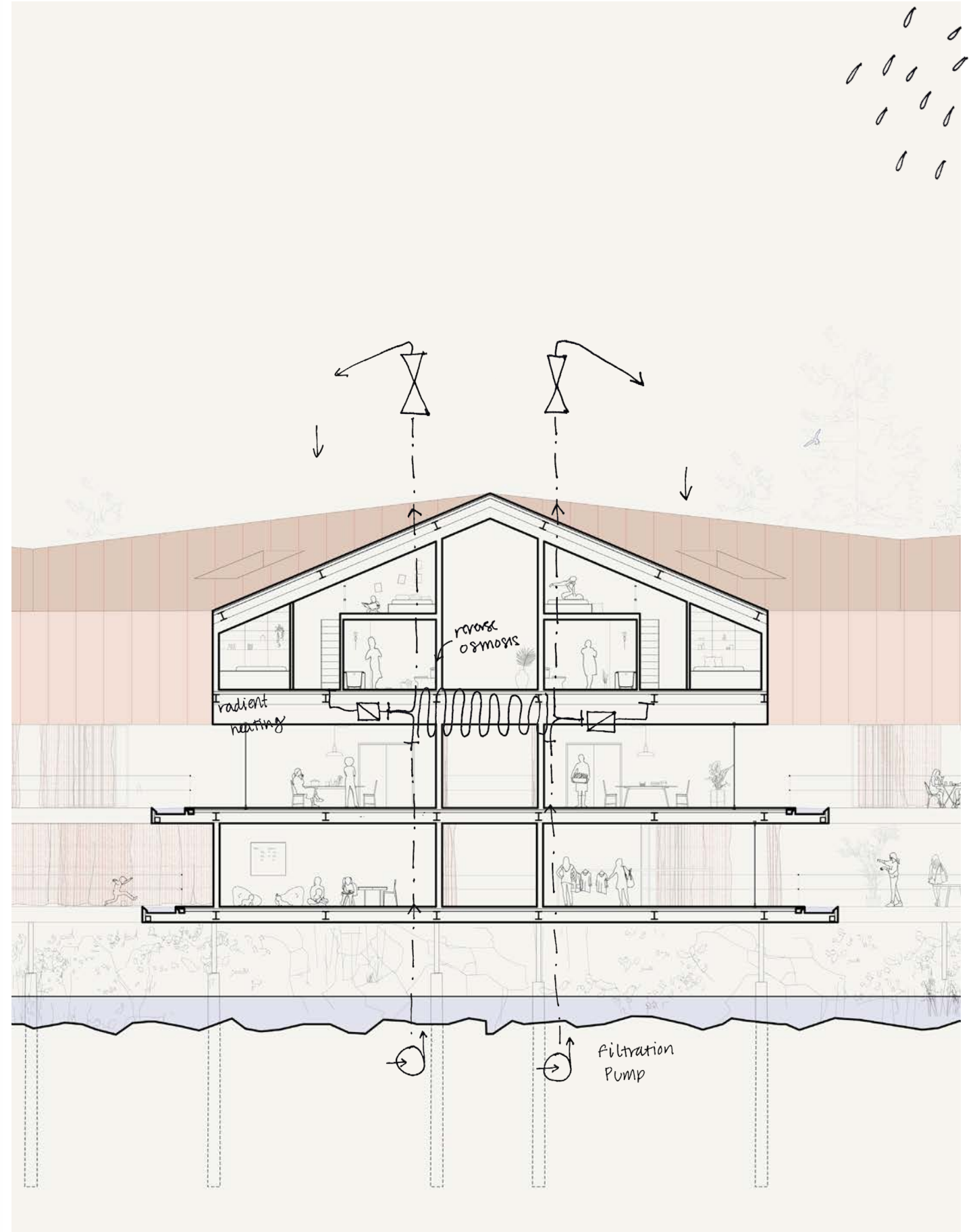

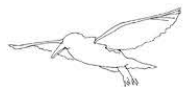
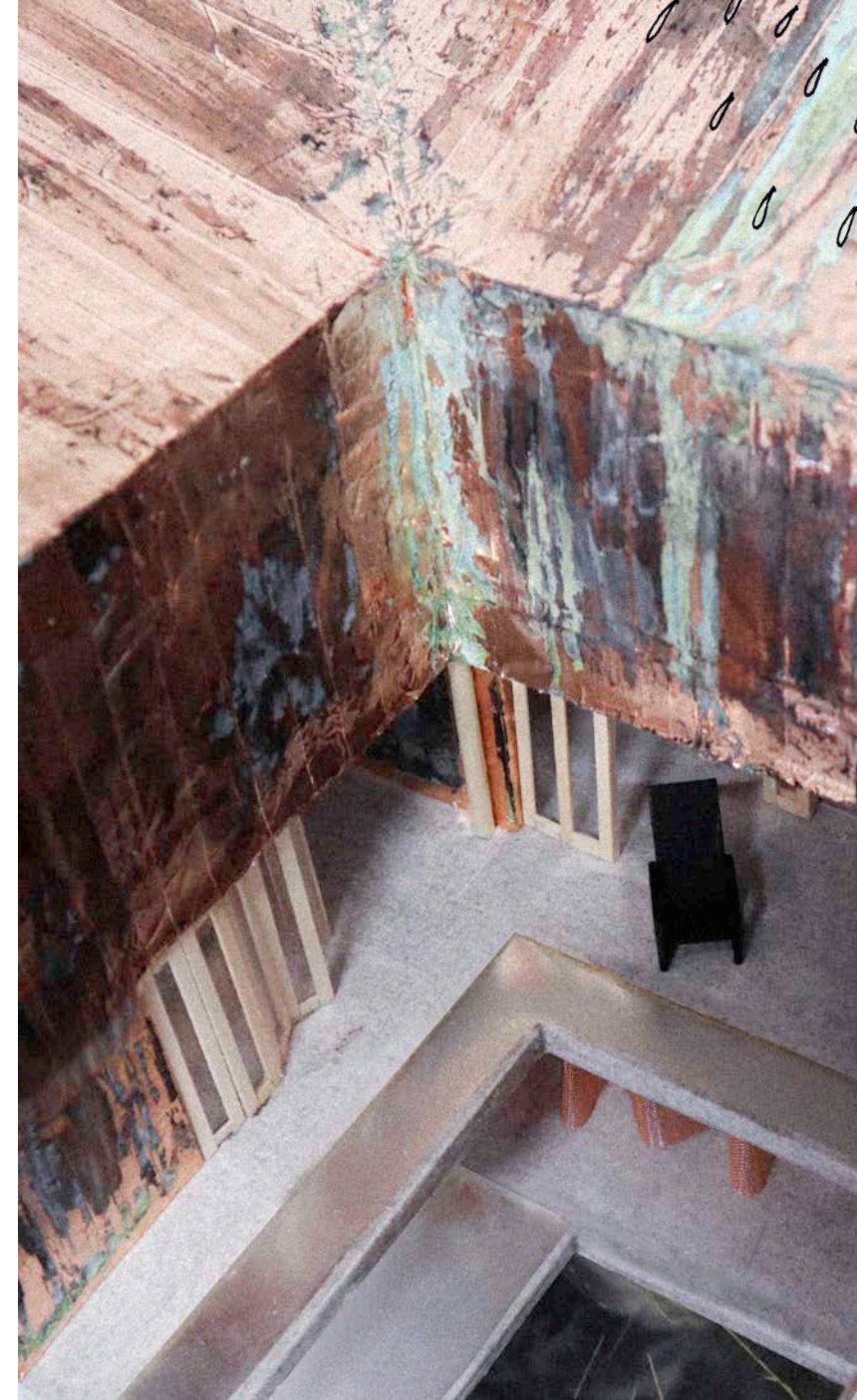



courtyard view



*Works Cited*

- 1a. "New Guinea, Hyde Park - Dutchess County Historical Society." Hyde Park's New Guinea Community, January 25, 2024.
- 1b. Ibid.
- 1c. Lesso, Rosie. "Power and Purpose: The History of African American Quilting." *The Thread*, October 20, 2020.
- 2a. Fondazione Giorgio Cini, Archival Library.
- 2b. Agnoletti, Mauro. "From the Dolomites to Venice: Rafts and River Driving along the Piave River in Italy (13th to 20th Centuries)." *IA. The Journal of the Society for Industrial Archeology* 21, no. 1 (1995): 15–32.
- 2c. Fondazione Giorgio Cini, Archival Library.
- 2d. Ibid.
- 2e. Ibid.
- 3a. "Seneca Village Unearthed." Digital Exhibitions.
- 3b. "South Africa - Trust for African Rock Art." Trust For African Rock Art - Prehistoric African Paintings and Engravings, December 17, 2022.
- 3c. Frederick Law Olmsted and Calvert Vaux, Greensward Plan for Central Park, 1858. Presentation board no. 5 from point E. Department of Parks and Recreation collection, New York City Municipal Archives.
- 4a. Davis, Sharon. "Recreating the Late 1930s Savoy." *Welcome to The Savoy*.
- 4b. Lai, Stephanie. "Morningside Park Is Essential to Harlem's Identity. How Has the University Misunderstood Resident Challenges in the Public Space?" *Columbia Daily Spectator*, January 22, 2020.
- 4c. Cornell Capa, "Gladys Crowder & Eddie Shorty Davis dance at the Savoy, 1939"
- 7a. McFarlane, Scot. "Reconnecting with the Harlem River." *The Gotham Center for New York City History*, November 12, 2020.
- 7b. "Harlem River." *Confluence: The History of North American Rivers*.
- 7c. Lionel Pincus and Princess Firyal Map Division, The New York Public Library. "Sanitary & topographical map of the city and island of New York." *New York Public Library Digital Collections*.
- 7d. "Bridges of Metro-North: The Harlem River Lift Bridge." *Ride The Harlem Line*, December 19, 2014.



*The
Practice
of Care.*
